

SEK connectors for flat cables enable simple and –, cost-optimized device configuration. SEK connectors are preferably used for connection within the device. HARTING offers a broad range of these cable-to-board connectors.

Assembly on the cable side takes place in one work step for all contacts via flat conductors. The SEK is an economical and reliable interface for data and signal applications in industry.

Application profile:

CONNECTION TYPE		ENVIRONMENT		APPLICATION						
Board to Board	Cable/Wire to Board	IP 20	IP 65 / IP 67	Data	Signal	Power	high performance			
							Data transfer rate	Shielding	Number of contacts, contact density	Voltage, working current
<input type="checkbox"/>	<input checked="" type="checkbox"/>	<input type="checkbox"/>	<input type="checkbox"/>	<input checked="" type="checkbox"/>	<input checked="" type="checkbox"/>	<input type="checkbox"/>	<input type="checkbox"/>	<input type="checkbox"/>	<input checked="" type="checkbox"/>	<input type="checkbox"/>
Cable termination			PCB termination			Application standard				
<i>Han-Quick Lock®</i>	<i>IDC</i>	<i>Crimp</i>	<i>THT</i>	<i>SMC</i>	<i>SMT</i>					
	 <input checked="" type="checkbox"/>		 <input type="checkbox"/>	 <input checked="" type="checkbox"/>						
<i>Screw</i>	<i>Cage clamp</i>	<i>Axial screw</i>	<i>Press-in</i>							
			 <input checked="" type="checkbox"/>							
						<i>Housing integration</i>				
						<i>Separate housing</i>		<i>Integrated housing</i>		

CONTENTS	PAGE
SEK connector system – introduction	08.02
General information	08.05
Solder board connectors	08.06
Male standard connectors	08.08
Male low-profile connectors	08.16
Accessories	08.18
Wrap post connectors	
Male standard connectors	08.19
Accessories	08.22
Cable connectors	
Female connectors	08.23
Pcb transition connectors, 2 rows	08.26
Pcb transition connectors, 4 rows	08.28
DIP connectors	08.30
DIN 41 612 connectors	08.32
Press-in connectors	
Male standard connectors	08.34
Male low-profile connectors	08.38
SMC solder board connectors	
Male standard SMC connectors	08.40
Male low-profile SMC connectors	08.50
Accessories	08.52
Cables and cable assemblies	08.53

Tooling see chapter 20

**IDC CONNECTOR SYSTEM [2.54 mm X 2.54 mm PITCH]  
FOR FLAT CABLES**

HARTING's product range of flat cable connectors is designed for various cable-to-PCB applications. The HARTING SEK insulation displacement connector technology meets all requirements of the IEC 60 603-13.

HARTING assembles each SEK connector with the matching cable type according to customer specifications in order to simplify customer installation and storage.

The different types of board connectors offer 6 to 64 pins in various terminations such as solder (manual, wave or reflow) or press-in.

The cable connectors are equally suited for indoor use as well as for outdoor applications and harsh environments.



## CABLE ASSEMBLIES

- HARTING can supply cable assemblies according to your specifications.
- A wide range of connector types available with various contact arrangements constitute the ideal solution to your wiring problems.
- Cables of all types in economic reel lengths are available.

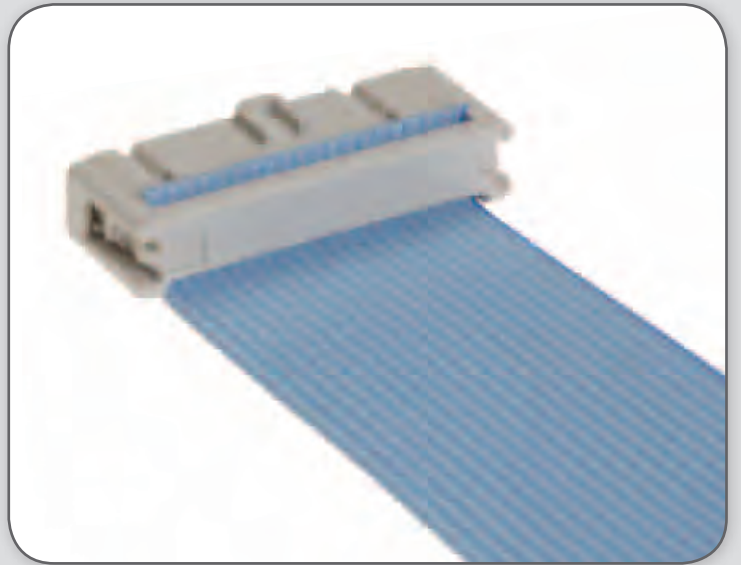

## QUALITY

- Cables professionally assembled on HARTING work stations ensure reliable connections.
- Finished harnesses are subject to 100% quality checks on a HARTING test device.
- Insulation test by 1000 V.
- Contact resistance test.

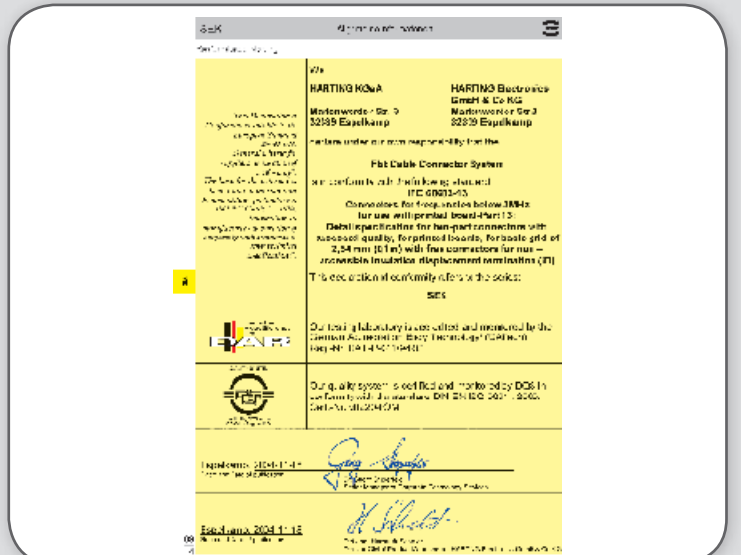

## ECONOMY

- The tested assembly of connectors and flat cables from one manufacturer guarantees a high degree of economy and reliability.
- Investments for work stations and test devices are not required.
- Stocks of piece parts are reduced.



SEK

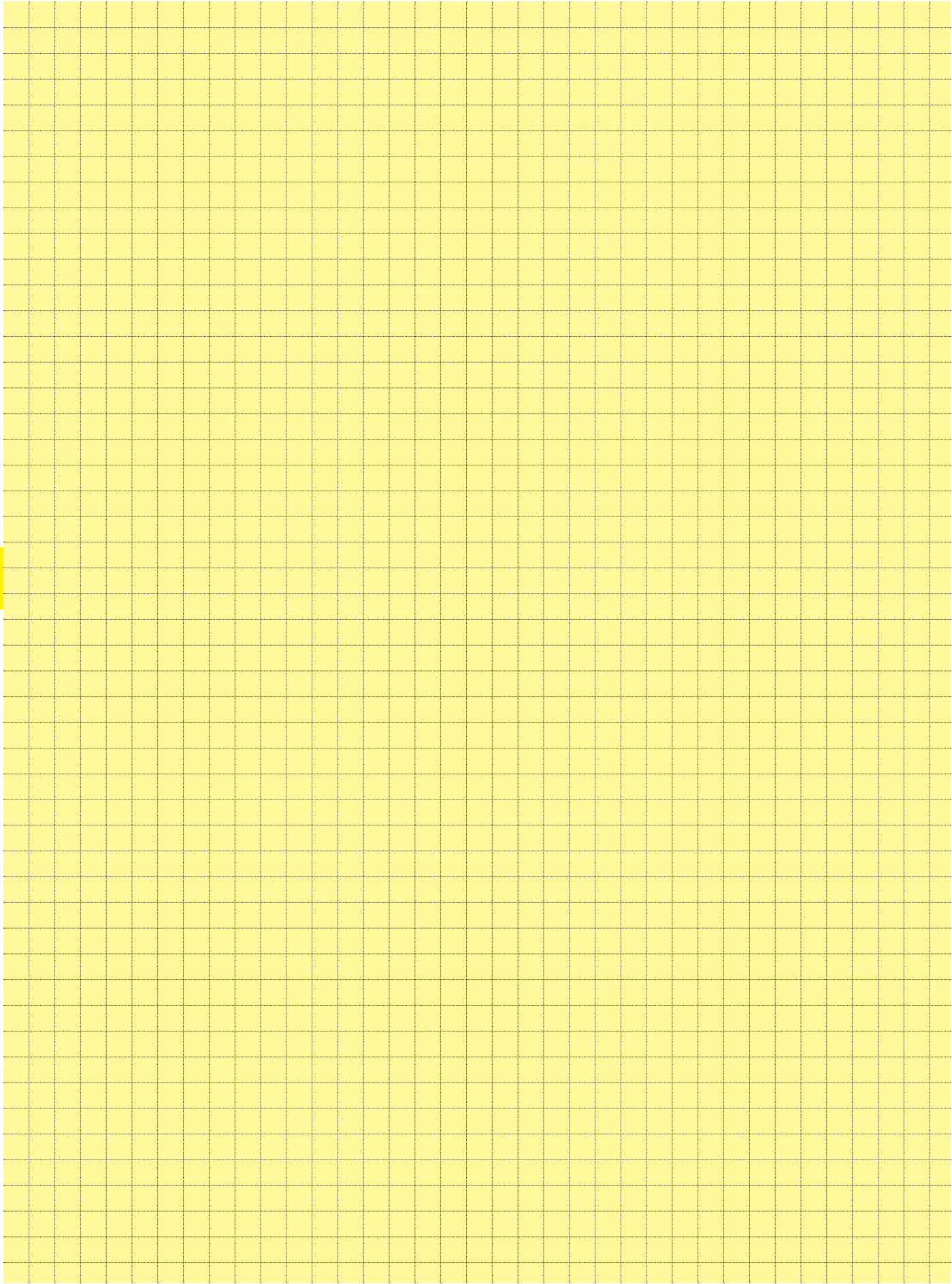

## The HARTING Insulation Displacement Connector system

### Economic and reliable connections

The flat cable and connector can be preassembled and used as a component with predetermined functional characteristics.

The HARTING insulation displacement contacts pierce the insulation on the flat cable to provide a durable gastight connection with the wire.

The HARTING insulation displacement technique constitutes the ideal solution to your wiring problems.

For "non standard applications" we can manufacture designs to match your requirements. Please discuss requirements with us.

HARTING SEK connectors incorporate the latest design features and provide the assurance of high quality and reliability with economy.

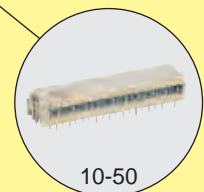
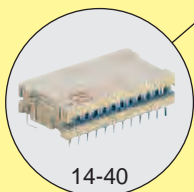
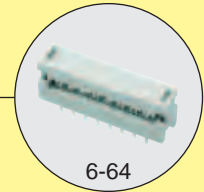
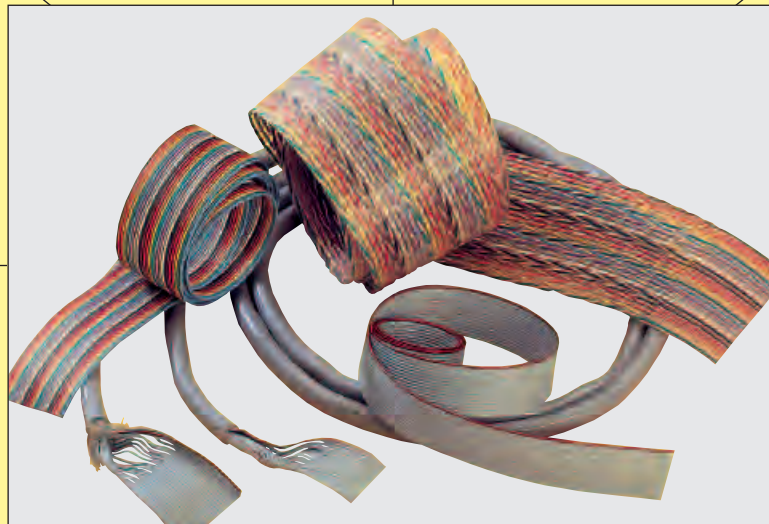
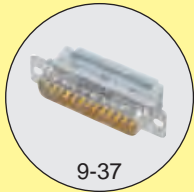
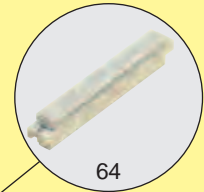
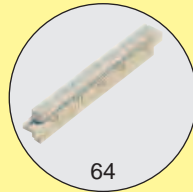
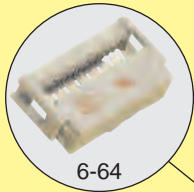

#### Cable assemblies

- HARTING can supply cable assemblies to customer specifications.
- A wide range of connector types available with various contact arrangements constitute the ideal solution to your wiring problems.
- Cables of all types in economic reel lengths are available.

#### Quality

- Cables professionally assembled on HARTING work stations ensure reliable connections.
- Finished harnesses are subject to 100% quality checks on a HARTING test device.
- Insulation test.
- Contact resistance test.

#### Economy

- The tested assembly of connectors and flat cables from one manufacturer guarantees a high degree of economy and reliability.
- Investment for work stations and test devices are not required.
- Stocks of piece parts are reduced.

SEK

Number of contacts 6, 10, 14, 16, 20, 26, 30, 34, 40, 50, 60, 64

Contact arrangement straight, angled

Contact length 2.9 mm, 4.5 mm

Approvals IEC 60603-13  
DIN EN 60603-13  
D 2632  
BT 224  
NFC 93-428 (HE 10)  
UL recognized: E102079



Pitch 2.54 mm [0.100"]

Working current 1 A

Working voltage 500 V  
for pollution degree 1

Test voltage  $U_{r.m.s.}$  1 kV

Contact resistance  $\leq 20 \text{ m}\Omega$   
Insulation resistance  $\geq 10^9 \Omega$

Temperature range -55 °C ... +125 °C  
The maximum temperature includes heating of contacts and ambient temperature

Terminations For pcb hole  $\varnothing 1 \pm 0.1 \text{ mm}$   
DIN IEC 52 141  
Diagonal: 0.79 mm

Materials Moulding Thermoplastic resin (PBT)  
UL 94-V0

Contact surface Contact zone gold-plated according to performance level<sup>1)</sup>

### Current carrying capacity

The current carrying capacity is limited by maximum temperature of materials for inserts and contacts including terminals. The current capacity-curve is valid for continuous, not interrupted current-loaded contacts of connectors when simultaneous power on all contacts is given, without exceeding the maximum temperature.

Control and test procedures according to DIN IEC 60512.

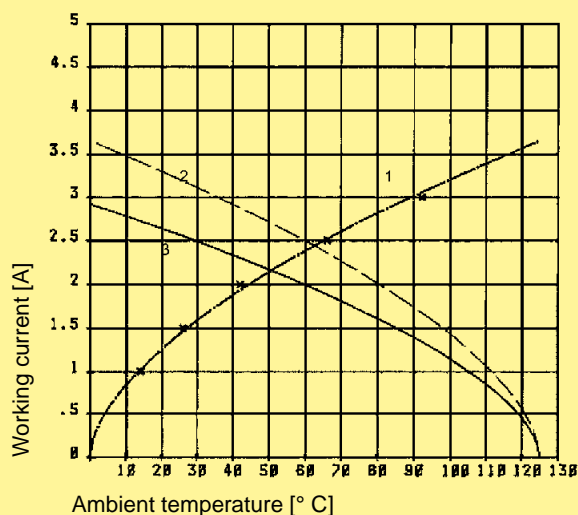

Example: 50 way connector

- ① Temperature rise
- ② Derating
- ③ Derating curve at  $I_{max} \times 0.8$  (IEC 60512-2)

### Insertion and withdrawal forces

Number of contacts	Maximum force [N]	
	Performance level 1 and 2	Performance level 3
6	12	18
10	20	30
14	28	42
16	32	48
20	40	60
26	52	78
30	60	90
34	68	102
40	80	120
50	100	150
60	120	180
64	128	192

<sup>1)</sup> Performance level 3 as per IEC 60603-13,  $\geq 50$  mating cycles, no gas test  
Performance level 2 as per IEC 60603-13,  $\geq 250$  mating cycles, 4 days gas test  
S4, plating  $> 0.76 \mu\text{m Au}$  ( $30 \mu\text{inch}$ ) or equivalent PdNi

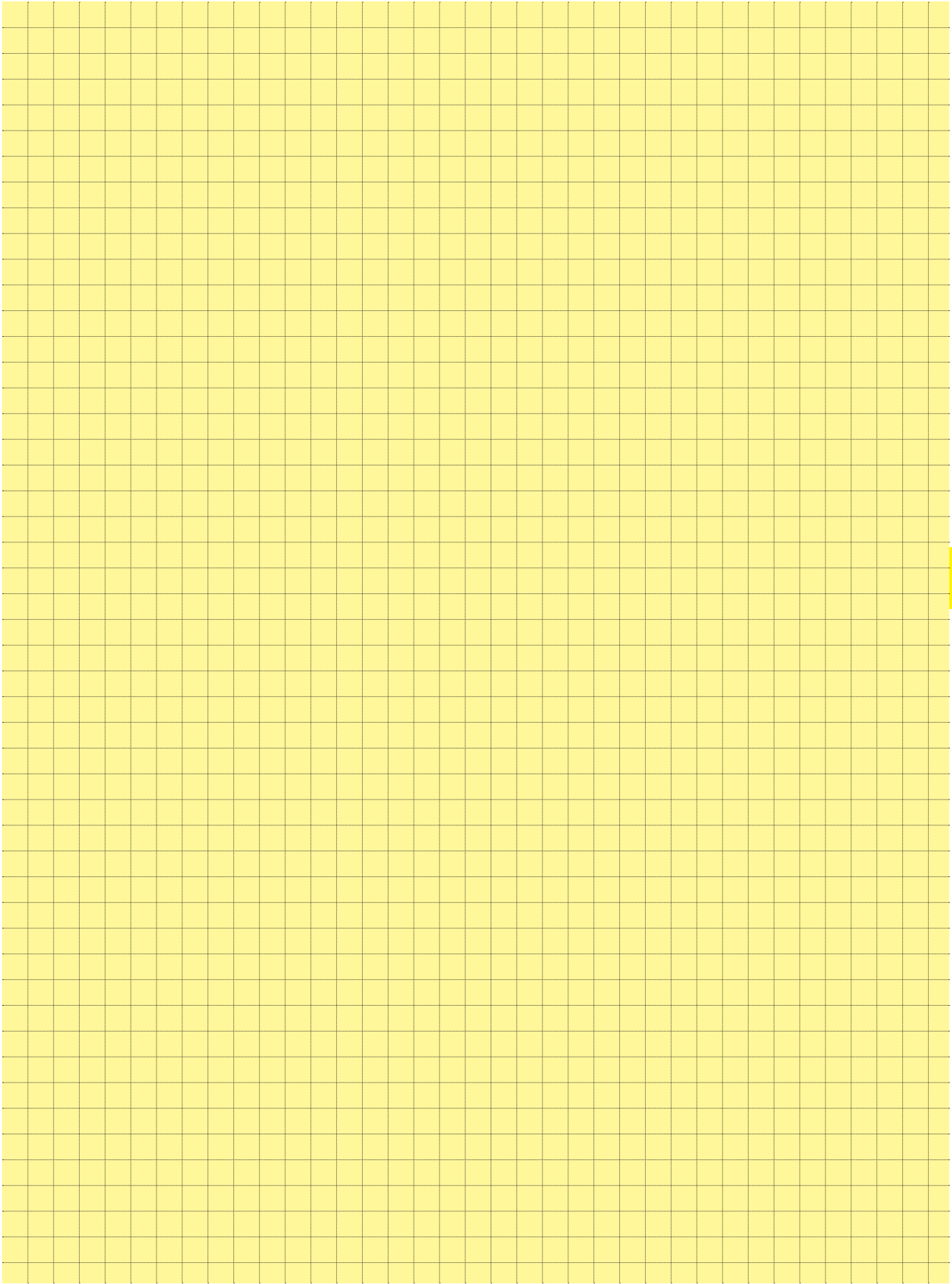



Number of contacts

**6-64**

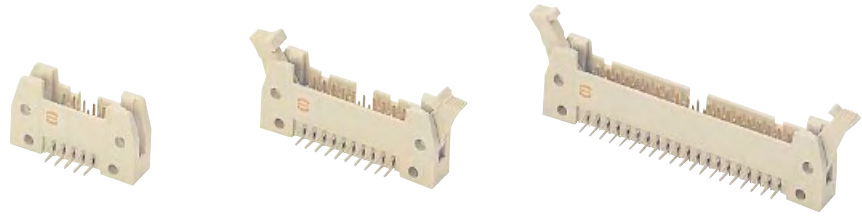

Male header with angled solder pins

Identification	No. of contacts	Part No.					
		Without levers		With short levers		With long levers	
<b>Male header with angled solder pins</b> Length: 2.9 mm							
	6	09 18 506	└ 923	09 18 506	└ 913	09 18 506	└ 903
	10	09 18 510	└ 923	09 18 510	└ 913	09 18 510	└ 903
	14	09 18 514	└ 923	09 18 514	└ 913	09 18 514	└ 903
	16	09 18 516	└ 923	09 18 516	└ 913	09 18 516	└ 903
	20	09 18 520	└ 923	09 18 520	└ 913	09 18 520	└ 903
	26	09 18 526	└ 923	09 18 526	└ 913	09 18 526	└ 903
	30	09 18 530	└ 923	09 18 530	└ 913	09 18 530	└ 903
	34	09 18 534	└ 923	09 18 534	└ 913	09 18 534	└ 903
	40	09 18 540	└ 923	09 18 540	└ 913	09 18 540	└ 903
	50	09 18 550	└ 923	09 18 550	└ 913	09 18 550	└ 903
	60	09 18 560	└ 923	09 18 560	└ 913	09 18 560	└ 903
	64	09 18 564	└ 923	09 18 564	└ 913	09 18 564	└ 903
Kinked version on request							
<b>Male header with angled solder pins</b> Length: 4.5 mm							
	6	09 18 506	└ 921*	09 18 506	└ 911*	09 18 506	└ 901*
	10	09 18 510	└ 921*	09 18 510	└ 911*	09 18 510	└ 901*
	14	09 18 514	└ 921*	09 18 514	└ 911*	09 18 514	└ 901*
	16	09 18 516	└ 921*	09 18 516	└ 911*	09 18 516	└ 901*
	20	09 18 520	└ 921*	09 18 520	└ 911*	09 18 520	└ 901*
	26	09 18 526	└ 921*	09 18 526	└ 911*	09 18 526	└ 901*
	30	09 18 530	└ 921*	09 18 530	└ 911*	09 18 530	└ 901*
	34	09 18 534	└ 921*	09 18 534	└ 911*	09 18 534	└ 901*
	40	09 18 540	└ 921*	09 18 540	└ 911*	09 18 540	└ 901*
	50	09 18 550	└ 921*	09 18 550	└ 911*	09 18 550	└ 901*
	60	09 18 560	└ 921*	09 18 560	└ 911*	09 18 560	└ 901*
	64	09 18 564	└ 921*	09 18 564	└ 911*	09 18 564	└ 901*
Kinked version on request							

SEK

08  
08

\* Not normally kept in stock  
 For accessories see page 08.18  
 For dimensions see page 08.09

For performance level 3 please specify digit  
 For performance level 2 please specify digit  
 S4 > 0.76 µm Au (30 µ inch) or equivalent PdNi

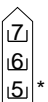
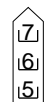

Number of contacts

# 6-64

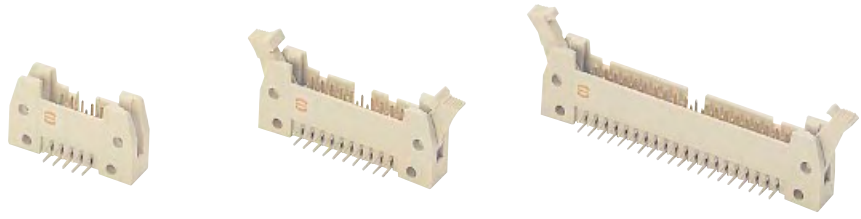

Male header with angled solder pins

Identification

Drawing

Dimensions in mm

Male header

No. of contacts	A	B	D	E	F	G
6	26.9	16.76	12.45	2.54 x 2 = 5.08	36.9	40.3
10	32.0	21.84	17.53	2.54 x 4 = 10.16	42.0	45.4
14	37.1	26.92	22.61	2.54 x 6 = 15.24	47.1	50.4
16	39.6	29.46	25.15	2.54 x 7 = 17.78	49.6	53.0
20	44.7	34.54	30.23	2.54 x 9 = 22.86	54.7	58.1
26	52.3	42.16	37.85	2.54 x 12 = 30.48	62.3	65.7
30	57.7	47.24	43.83	2.54 x 14 = 35.56	68.2	68.6
34	62.5	52.32	48.01	2.54 x 16 = 40.64	72.5	75.8
40	70.1	59.94	55.63	2.54 x 19 = 48.26	80.1	83.5
50	82.8	72.64	68.33	2.54 x 24 = 60.96	92.8	96.2
60	95.5	85.34	81.03	2.54 x 29 = 73.66	105.5	108.9
64	100.6	90.42	86.11	2.54 x 31 = 78.74	110.6	113.9

### Short levers

for use with female connector without strain relief clamp

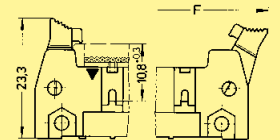
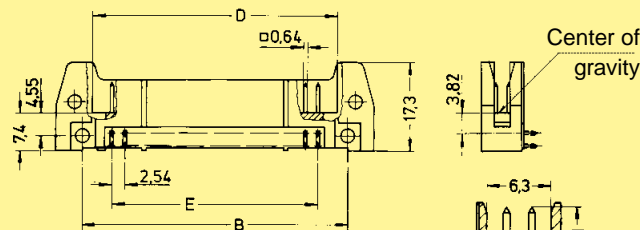

### Long levers

for use with female connector with strain relief clamp

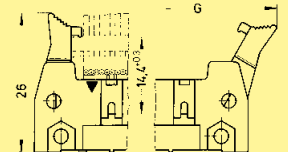
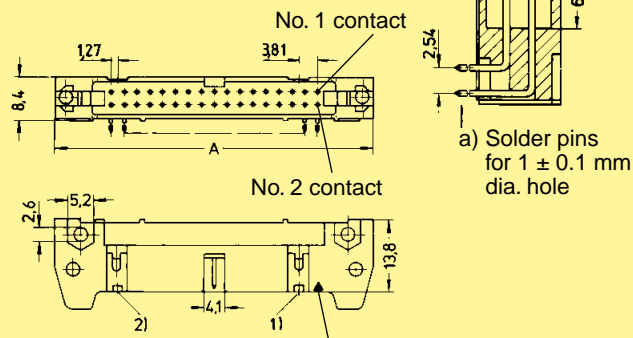

Marking No. 1 contact

No. 1 contact

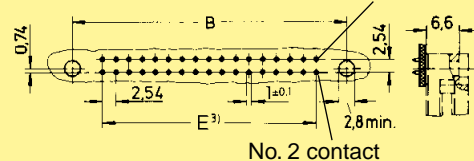

Board drillings

For accessories see page 08.18

<sup>1)</sup> No polarization slot for 6, 10 or 14 way male header

<sup>2)</sup> No polarization slot for 6 way male header

<sup>3)</sup> Pitch tolerance: ± 0.1

Number of contacts

# 6-64

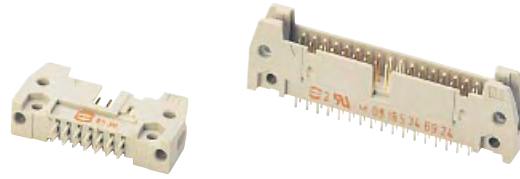

Male header with straight solder pins

Identification	No. of contacts	Part No.						
		Without levers		With short levers		With long levers		
Male header with straight solder pins Length: 2.9 mm	6	09 18 506	└ 924	09 18 506	└ 914	09 18 506	└ 904	
	10	09 18 510	└ 924	09 18 510	└ 914	09 18 510	└ 904	
	14	09 18 514	└ 924	09 18 514	└ 914	09 18 514	└ 904	
	16	09 18 516	└ 924	09 18 516	└ 914	09 18 516	└ 904	
	20	09 18 520	└ 924	09 18 520	└ 914	09 18 520	└ 904	
	26	09 18 526	└ 924	09 18 526	└ 914	09 18 526	└ 904	
	30	09 18 530	└ 924	09 18 530	└ 914	09 18 530	└ 904	
	34	09 18 534	└ 924	09 18 534	└ 914	09 18 534	└ 904	
	40	09 18 540	└ 924	09 18 540	└ 914	09 18 540	└ 904	
	50	09 18 550	└ 924	09 18 550	└ 914	09 18 550	└ 904	
	60	09 18 560	└ 924	09 18 560	└ 914	09 18 560	└ 904	
	64	09 18 564	└ 924	09 18 564	└ 914	09 18 564	└ 904	
	Male header with straight solder pins Length: 4.5 mm	6	09 18 506	└ 922*	09 18 506	└ 912*	09 18 506	└ 902*
		10	09 18 510	└ 922*	09 18 510	└ 912*	09 18 510	└ 902*
14		09 18 514	└ 922*	09 18 514	└ 912*	09 18 514	└ 902*	
16		09 18 516	└ 922*	09 18 516	└ 912*	09 18 516	└ 902*	
20		09 18 520	└ 922*	09 18 520	└ 912*	09 18 520	└ 902*	
26		09 18 526	└ 922*	09 18 526	└ 912*	09 18 526	└ 902*	
30		09 18 530	└ 922*	09 18 530	└ 912*	09 18 530	└ 902*	
34		09 18 534	└ 922*	09 18 534	└ 912*	09 18 534	└ 902*	
40		09 18 540	└ 922*	09 18 540	└ 912*	09 18 540	└ 902*	
50		09 18 550	└ 922*	09 18 550	└ 912*	09 18 550	└ 902*	
60		09 18 560	└ 922*	09 18 560	└ 912*	09 18 560	└ 902*	
64		09 18 564	└ 922*	09 18 564	└ 912*	09 18 564	└ 902*	

SEK

08  
10

Kinked version on request

\* Not normally kept in stock  
 For accessories see page 08.18  
 For dimensions see page 08.11

For performance level 3 please specify digit  
 For performance level 2 please specify digit  
 S4 > 0.76 µm Au (30 µ inch) or equivalent PdNi

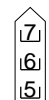

Number of contacts

# 6-64

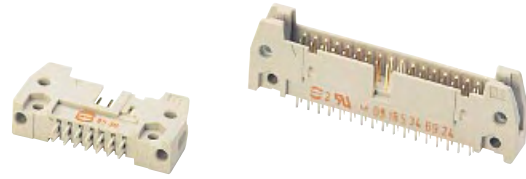

Male header with straight solder pins

Identification

Drawing

Dimensions in mm

Male header

No. of contacts	A	C	D	E	F	G
6	26.9	22.86	12.45	2.54 x 2 = 5.08	36.9	40.3
10	32.0	27.94	17.53	2.54 x 4 = 10.16	42.0	45.4
14	37.1	33.02	22.61	2.54 x 6 = 15.24	47.1	50.4
16	39.6	35.56	25.15	2.54 x 7 = 17.78	49.6	53.0
20	44.7	40.64	30.23	2.54 x 9 = 22.86	54.7	58.1
26	52.3	48.26	37.85	2.54 x 12 = 30.48	62.3	65.7
30	57.7	53.34	43.83	2.54 x 14 = 35.56	68.2	68.6
34	62.5	58.42	48.01	2.54 x 16 = 40.64	72.5	75.8
40	70.1	66.04	55.63	2.54 x 19 = 48.26	80.1	83.5
50	82.8	78.74	68.33	2.54 x 24 = 60.96	92.8	96.2
60	95.5	91.44	81.03	2.54 x 29 = 73.66	105.5	108.9
64	100.6	96.52	86.11	2.54 x 31 = 78.74	110.6	113.9

### Short levers

for use with female connector without strain relief clamp

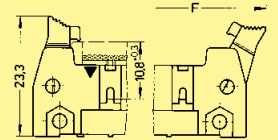
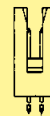
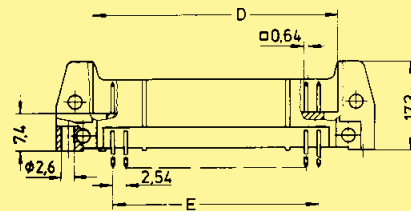

### Long levers

for use with female connector with strain relief clamp

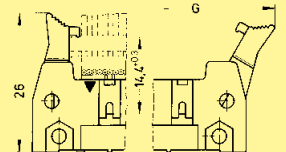
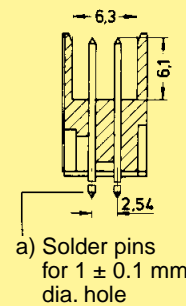
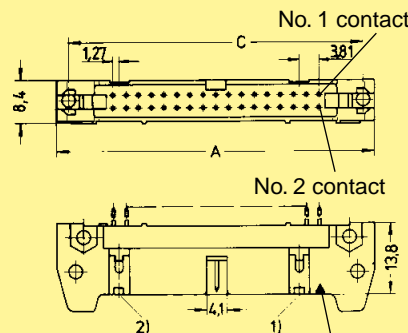

Marking No. 1 contact

Board drillings

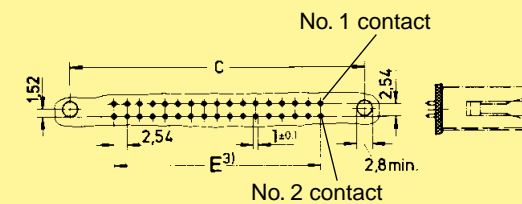

For accessories see page 08.18

<sup>1)</sup> No polarization slot for 6, 10 or 14 way male header

<sup>2)</sup> No polarization slot for 6 way male header

<sup>3)</sup> Pitch tolerance: ± 0.1

Number of contacts

6-64

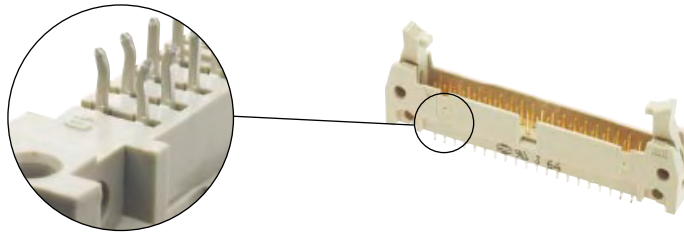

Male header with straight solder pins, kinked

Identification	No. of contacts	Part No.		
		Without levers	With short levers	With long levers

Male header with straight solder pins, kinked  
Length: 2.9 mm

6	09 18 506	└ 024	09 18 506	└ 014	09 18 506	└ 004
10	09 18 510	└ 024	09 18 510	└ 014	09 18 510	└ 004
14	09 18 514	└ 024	09 18 514	└ 014	09 18 514	└ 004
16	09 18 516	└ 024	09 18 516	└ 014	09 18 516	└ 004
20	09 18 520	└ 024	09 18 520	└ 014	09 18 520	└ 004
26	09 18 526	└ 024	09 18 526	└ 014	09 18 526	└ 004
30	09 18 530	└ 024	09 18 530	└ 014	09 18 530	└ 004
34	09 18 534	└ 024	09 18 534	└ 014	09 18 534	└ 004
40	09 18 540	└ 024	09 18 540	└ 014	09 18 540	└ 004
50	09 18 550	└ 024	09 18 550	└ 014	09 18 550	└ 004
60	09 18 560	└ 024	09 18 560	└ 014	09 18 560	└ 004
64	09 18 564	└ 024	09 18 564	└ 014	09 18 564	└ 004

SEK

\* Not normally kept in stock  
For accessories see page 08.18  
For dimensions see page 08.13

For performance level 3 please specify digit  
For performance level 2 please specify digit  
S4 > 0.76 µm Au (30 µ inch) or equivalent PdNi

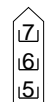
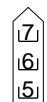
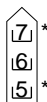

Number of contacts

# 6-64

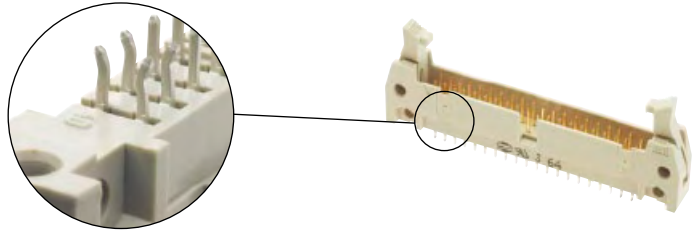

Male header with straight solder pins, kinked

Identification

Drawing

Dimensions in mm

Male header

No. of contacts	A	C	D	E	F	G
6	26.9	22.86	12.45	2.54 x 2 = 5.08	36.9	40.3
10	32.0	27.94	17.53	2.54 x 4 = 10.16	42.0	45.4
14	37.1	33.02	22.61	2.54 x 6 = 15.24	47.1	50.4
16	39.6	35.56	25.15	2.54 x 7 = 17.78	49.6	53.0
20	44.7	40.64	30.23	2.54 x 9 = 22.86	54.7	58.1
26	52.3	48.26	37.85	2.54 x 12 = 30.48	62.3	65.7
30	57.7	53.34	43.83	2.54 x 14 = 35.56	68.2	68.6
34	62.5	58.42	48.01	2.54 x 16 = 40.64	72.5	75.8
40	70.1	66.04	55.63	2.54 x 19 = 48.26	80.1	83.5
50	82.8	78.74	68.33	2.54 x 24 = 60.96	92.8	96.2
60	95.5	91.44	81.03	2.54 x 29 = 73.66	105.5	108.9
64	100.6	96.52	86.11	2.54 x 31 = 78.74	110.6	113.9

### Short levers

for use with female connector without strain relief clamp

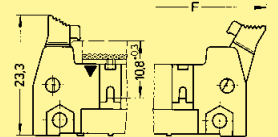
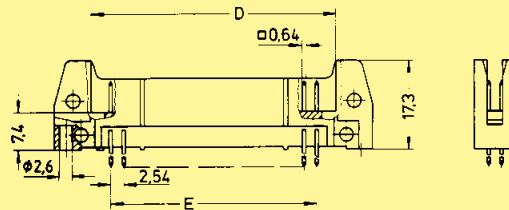

### Long levers

for use with female connector with strain relief clamp

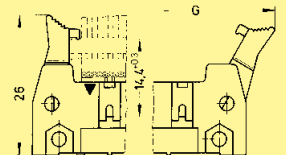
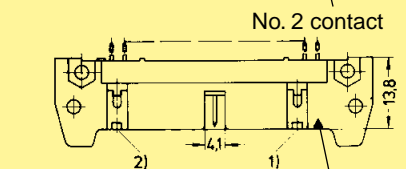
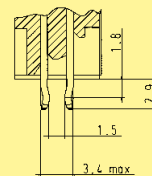
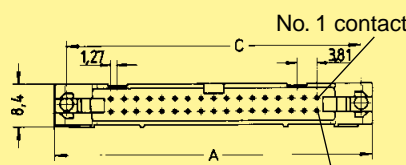

Marking No. 1 contact

No. 1 contact

Board drillings

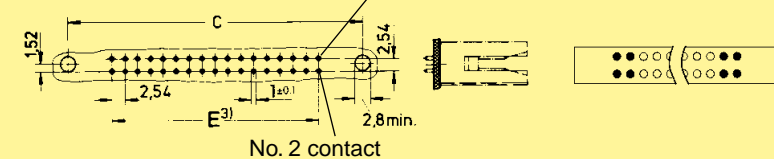

● Kinked contact: pcb thickness from 1.50 to 1.94 mm after Cu + Sn plating with non-remelted through holes  $\varnothing$  0.80 to  $\varnothing$  0.95 mm. Max. insertion force = 125 N. Min. retention force = 3 N.

○ Non-kinked contact: Solder pins for pcb connections  $\varnothing$   $1 \pm 0.1$  mm as per IEC 60603-13.

<sup>1)</sup> No polarization slot for 6, 10 or 14 way male header

<sup>2)</sup> No polarization slot for 6 way male header

<sup>3)</sup> Pitch tolerance:  $\pm 0.1$

Number of contacts

# 6-64

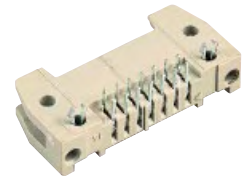

Male header with angled solder pins and board lock

Identification	No. of contacts	Part No.					
		Without levers		With short levers		With long levers	
<p>Male header with angled solder pins and pcb board lock</p> <p>Length: 2.9 mm for 1.6 mm pcb thickness</p> <p>To hold the connector on the pcb before the soldering process, two board locks have been added on the male header with angled solder pins.</p>	6	09 18 506	└ 973*	09 18 506	└ 963*	09 18 506	└ 953*
	10	09 18 510	└ 973*	09 18 510	└ 963*	09 18 510	└ 953*
	14	09 18 514	└ 973*	09 18 514	└ 963*	09 18 514	└ 953*
	16	09 18 516	└ 973*	09 18 516	└ 963*	09 18 516	└ 953*
	20	09 18 520	└ 973*	09 18 520	└ 963*	09 18 520	└ 953*
	26	09 18 526	└ 973*	09 18 526	└ 963*	09 18 526	└ 953*
	30	09 18 530	└ 973*	09 18 530	└ 963*	09 18 530	└ 953*
	34	09 18 534	└ 973*	09 18 534	└ 963*	09 18 534	└ 953*
	40	09 18 540	└ 973*	09 18 540	└ 963*	09 18 540	└ 953*
	50	09 18 550	└ 973*	09 18 550	└ 963*	09 18 550	└ 953*
	60	09 18 560	└ 973*	09 18 560	└ 963*	09 18 560	└ 953*
	64	09 18 564	└ 973*	09 18 564	└ 963*	09 18 564	└ 953*

SEK

08  
14

\* Not normally kept in stock

For performance level 3 please specify digit  
 For performance level 2 please specify digit  
 S4 > 0.76 µm Au (30 µ inch) or equivalent PdNi

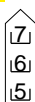
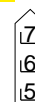
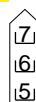

Number of contacts

# 6-64

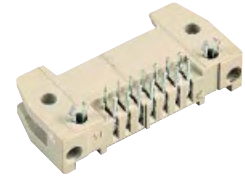

Male header with angled solder pins and board lock

Identification

Drawing

Dimensions in mm

Male header

No. of contacts	A	B	D	E	F	G
6	26.9	16.76	12.45	2.54 x 2 = 5.08	36.9	40.3
10	32.0	21.84	17.53	2.54 x 4 = 10.16	42.0	45.4
14	37.1	26.92	22.61	2.54 x 6 = 15.24	47.1	50.4
16	39.6	29.46	25.15	2.54 x 7 = 17.78	49.6	53.0
20	44.7	34.54	30.23	2.54 x 9 = 22.86	54.7	58.1
26	52.3	42.16	37.85	2.54 x 12 = 30.48	62.3	65.7
30	57.7	47.24	43.83	2.54 x 14 = 35.56	68.2	68.6
34	62.5	52.32	48.01	2.54 x 16 = 40.64	72.5	75.8
40	70.1	59.94	55.63	2.54 x 19 = 48.26	80.1	83.5
50	82.8	72.64	68.33	2.54 x 24 = 60.96	92.8	96.2
60	95.5	85.34	81.03	2.54 x 29 = 73.66	105.5	108.9
64	100.6	90.42	86.11	2.54 x 31 = 78.74	110.6	113.9

### Short levers

for use with female connector without strain relief clamp

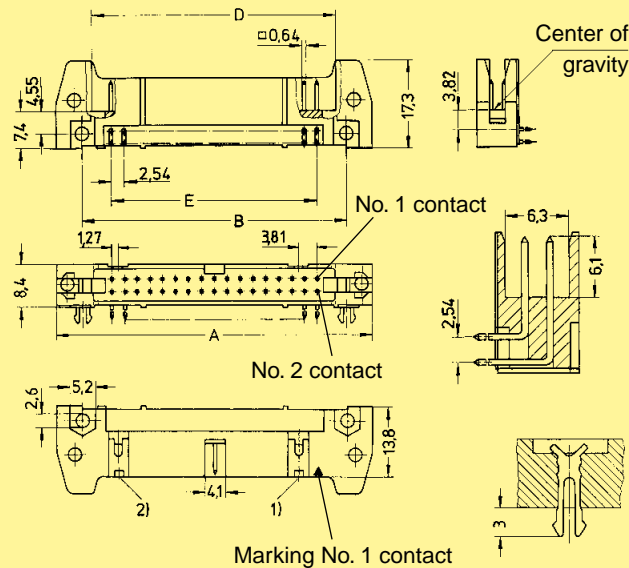

### Long levers

for use with female connector with strain relief clamp

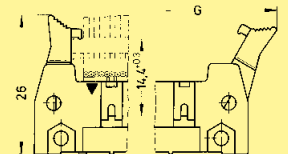

Board drillings

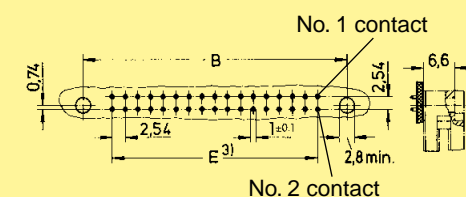

For accessories see page 08.18

<sup>1)</sup> No polarization slot for 6, 10 or 14 way male header

<sup>2)</sup> No polarization slot for 6 way male header  
<sup>3)</sup> Pitch tolerance: ± 0.1



Number of contacts

# 6-64

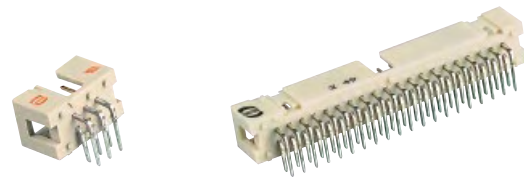

Low-profile male header, angled solder pins

Identification      No. of contacts      Part No.      Drawing      Dimensions in mm

Male header with angled solder pins

Length: 2.9 mm

6	09 18 506	┘ 323
10	09 18 510	┘ 323
14	09 18 514	┘ 323
16	09 18 516	┘ 323
20	09 18 520	┘ 323
26	09 18 526	┘ 323
30	09 18 530	┘ 323
34	09 18 534	┘ 323
40	09 18 540	┘ 323
50	09 18 550	┘ 323
60	09 18 560	┘ 323
64	09 18 564	┘ 323

No. of contacts	A	B	E
6	15.2	12.78	2.54 x 2 = 5.08
10	20.3	17.86	2.54 x 4 = 10.16
14	25.4	22.94	2.54 x 6 = 15.24
16	27.9	25.48	2.54 x 7 = 17.78
20	33.0	30.56	2.54 x 9 = 22.86
26	40.6	38.18	2.54 x 12 = 30.48
30	45.72	43.26	2.54 x 14 = 35.56
34	50.8	48.34	2.54 x 16 = 40.64
40	58.4	55.96	2.54 x 19 = 48.26
50	71.3	68.66	2.54 x 24 = 60.96
60	84.0	81.36	2.54 x 29 = 73.66
64	89.1	86.44	2.54 x 31 = 78.74

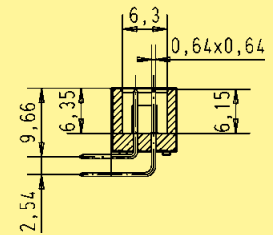

Solder pins for 1 ± 0.1 mm dia. hole

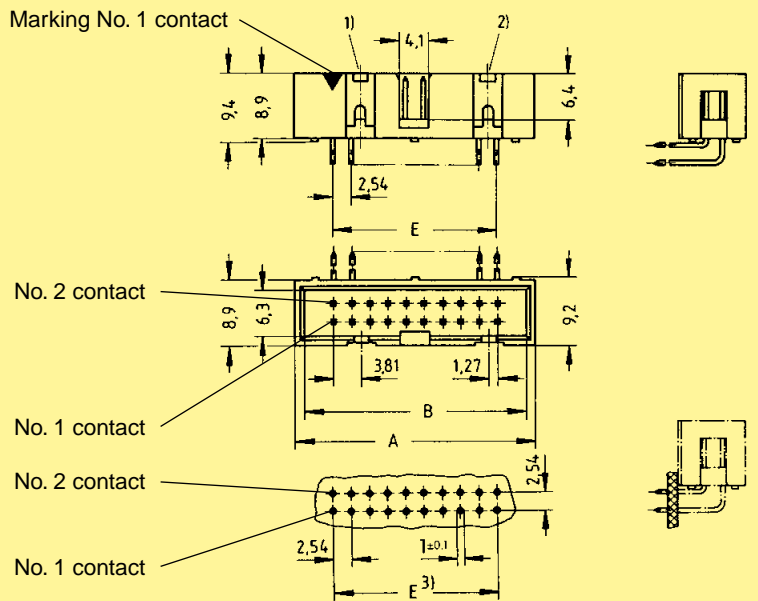

For performance level 3 please specify digit 7  
 For performance level 2 please specify digit 6  
 S4 > 0.76 µm Au (30 µ inch) or equivalent PdNi 5\*

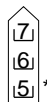

Identification      Part No.      Drawing      Dimensions in mm

Locking lever for female connector with strain relief in conjunction with low-profile male header

When the security of latching is required and space is a premium, these locking levers can be fitted onto the strain relief of the HARTING female connector.

09 18 000 9905<sup>4)</sup>

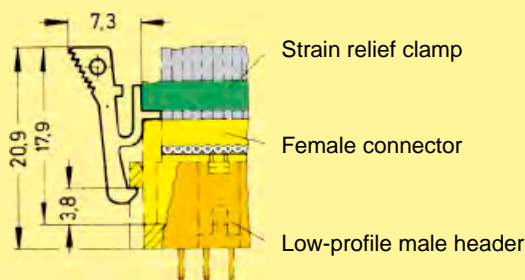

\* Not normally kept in stock

<sup>1)</sup> No polarization slot for 6, 10 or 14 way male header  
<sup>2)</sup> No polarization slot for 6 way male header

<sup>3)</sup> Pitch tolerance: ± 0.1  
<sup>4)</sup> Order 2 per female connector

Number of contacts

# 6-64



Low-profile male header, straight solder pins

Identification      No. of contacts      Part No.      Drawing      Dimensions in mm

Male header with straight solder pins

Length: 2.9 mm

6	09 18 506	└ 324
10	09 18 510	└ 324
14	09 18 514	└ 324
16	09 18 516	└ 324
20	09 18 520	└ 324
26	09 18 526	└ 324
30	09 18 530	└ 324
34	09 18 534	└ 324
40	09 18 540	└ 324
50	09 18 550	└ 324
60	09 18 560	└ 324
64	09 18 564	└ 324

No. of contacts	A	B	E
6	15.2	12.78	2.54 x 2 = 5.08
10	20.3	17.86	2.54 x 4 = 10.16
14	25.4	22.94	2.54 x 6 = 15.24
16	27.9	25.48	2.54 x 7 = 17.78
20	33.0	30.56	2.54 x 9 = 22.86
26	40.6	38.18	2.54 x 12 = 30.48
30	45.72	43.26	2.54 x 14 = 35.56
34	50.8	48.34	2.54 x 16 = 40.64
40	58.4	55.96	2.54 x 19 = 48.26
50	71.3	68.66	2.54 x 24 = 60.96
60	84.0	81.36	2.54 x 29 = 73.66
64	89.1	86.44	2.54 x 31 = 78.74

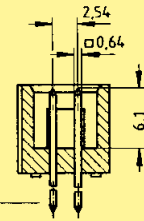

Solder pins for 1 ± 0.1 mm dia. hole

Male header with straight solder pins

Length: 4.5 mm

6	09 18 506	└ 322*
10	09 18 510	└ 322*
14	09 18 514	└ 322*
16	09 18 516	└ 322*
20	09 18 520	└ 322*
26	09 18 526	└ 322*
30	09 18 530	└ 322*
34	09 18 534	└ 322*
40	09 18 540	└ 322*
50	09 18 550	└ 322*
60	09 18 560	└ 322*
64	09 18 564	└ 322*

Marking No. 1 contact

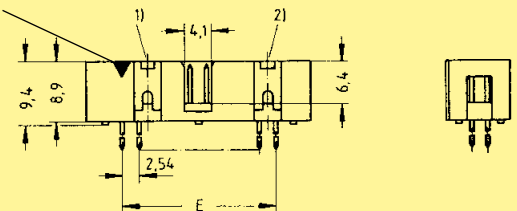

No. 2 contact

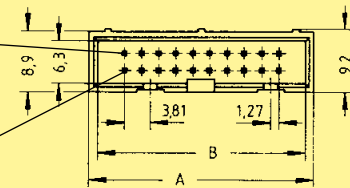

No. 1 contact

No. 2 contact

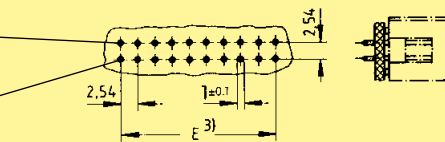

No. 1 contact

For performance level 3 please specify digit 7  
 For performance level 2 please specify digit 6  
 S4 > 0.76 µm Au (30 µ inch) or equivalent PdNi 5\*

Identification      Part No.      Drawing      Dimensions in mm

Locking lever for female connector with strain relief in conjunction with low-profile male header

When the security of latching is required and space is a premium, these locking levers can be fitted onto the strain relief of the HARTING female connector.

09 18 000 9905<sup>4)</sup>

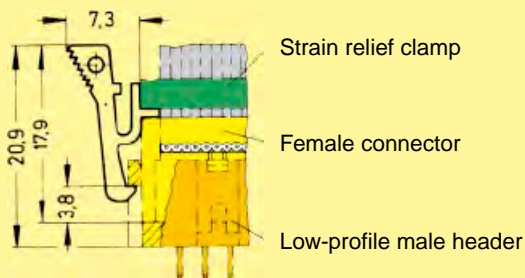

\* Not normally kept in stock

<sup>1)</sup> No polarization slot for 6, 10 or 14 way male header  
<sup>2)</sup> No polarization slot for 6 way male header

<sup>3)</sup> Pitch tolerance: ± 0.1  
<sup>4)</sup> Order 2 per female connector

Accessories

Identification	Part No.	Drawing	Dimensions in mm
<p>Polarization key</p> <p>1) Part No. comprises 2 keys</p>	09 18 500 9902 <sup>1)</sup>		
<p>Locking lever (snaps into place, can be fitted whenever required)</p> <p>2) Order 2 per male header</p>	<p>Long: 09 18 000 9903<sup>2)</sup></p> <p>Short: 09 18 000 9904<sup>2)</sup></p>	<p>Long</p> <p>Short</p> <p>For use with female connector <u>with</u> strain relief clamp</p> <p>For use with female connector <u>without</u> strain relief clamp</p>	
<p>Fixing screws for 1.6 mm P.C. board</p> <p>3) Part No. comprises 50 pieces</p>	09 18 000 9906 <sup>3)</sup>		<p>For connectors with part numbers 09 18 5xx x9xx: screwing torque 0.2 Nm 09 19 5xx x9xx: screwing torque 0.4 – 0.5 Nm</p> <p>Screw material: Steel (Inox A2)</p> <p>Plating: Nickel</p>
<p>Coding system with loss of contact</p> <p>4) Part No. comprises 6 code pins</p>	<p>Code pin 09 18 000 9901<sup>4)</sup></p> <p>Removal tool for male contacts 09 99 000 0133</p>	<p>To avoid cross-plugging adjacent connectors a coding system is required. A code pin is inserted into the appropriate cavity in the female connector. The corresponding male contact is removed by a special removal tool.</p>	

SEK

Number of contacts	6, 10, 14, 16, 20, 26, 30, 34, 40, 50, 60, 64
Contact arrangement	straight, angled
Contact length	15 mm
Approvals	IEC 60603-13 DIN EN 60603-13 D 2632 BT 224 NFC 93-428 (HE 10)
Pitch	2.54 mm [0.100"]
Working current	1 A
Working voltage	500 V for pollution degree 1
Test voltage $U_{r.m.s.}$	1 kV
Contact resistance	$\leq 20 \text{ m}\Omega$
Insulation resistance	$\geq 10^9 \Omega$
Temperature range	-55 °C ... +125 °C The maximum temperature includes heating of contacts and ambient temperature
Terminations	0.6 mm x 0.6 mm Diagonal: 0.86 mm
Materials	
Moulding	Thermoplastic resin (PBT) UL 94-V0
Contact surface	
Contact zone	gold-plated according to performance level <sup>1)</sup>

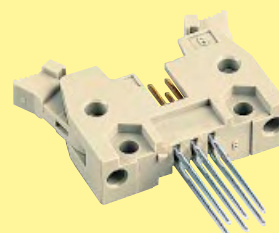

<sup>1)</sup> Performance level 3 as per IEC 60603-13,  $\geq 50$  mating cycles, no gas test  
Performance level 2 as per IEC 60603-13,  $\geq 250$  mating cycles, 4 days gas test  
S4, plating  $> 0.76 \mu\text{m Au}$  (30  $\mu$  inch) or equivalent PdNi

Number of contacts

# 6-64

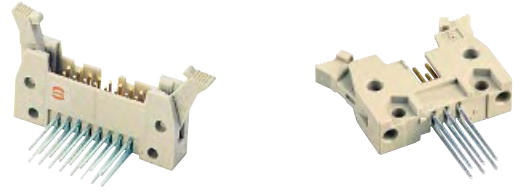

## Male header with wrap posts

Identification	No. of contacts	Part No.						
		Without levers		With short levers		With long levers		
<b>Male header with angled wrap posts</b> Length: 15 mm □ 0.6 mm	6	09 18 506	└ 926*	09 18 506	└ 916*	09 18 506	└ 906*	
	10	09 18 510	└ 926*	09 18 510	└ 916*	09 18 510	└ 906*	
	14	09 18 514	└ 926*	09 18 514	└ 916*	09 18 514	└ 906*	
	16	09 18 516	└ 926*	09 18 516	└ 916*	09 18 516	└ 906*	
	20	09 18 520	└ 926*	09 18 520	└ 916*	09 18 520	└ 906*	
	26	09 18 526	└ 926*	09 18 526	└ 916*	09 18 526	└ 906*	
	30	09 18 530	└ 926*	09 18 530	└ 916*	09 18 530	└ 906*	
	34	09 18 534	└ 926*	09 18 534	└ 916*	09 18 534	└ 906*	
	40	09 18 540	└ 926*	09 18 540	└ 916*	09 18 540	└ 906*	
	50	09 18 550	└ 926*	09 18 550	└ 916*	09 18 550	└ 906*	
	60	09 18 560	└ 926*	09 18 560	└ 916*	09 18 560	└ 906*	
	64	09 18 564	└ 926*	09 18 564	└ 916*	09 18 564	└ 906*	
	<b>Male header with straight wrap posts</b> Length: 15 mm □ 0.6 mm	6	09 18 506	└ 927*	09 18 506	└ 917*	09 18 506	└ 907*
		10	09 18 510	└ 927*	09 18 510	└ 917*	09 18 510	└ 907*
14		09 18 514	└ 927*	09 18 514	└ 917*	09 18 514	└ 907*	
16		09 18 516	└ 927*	09 18 516	└ 917*	09 18 516	└ 907*	
20		09 18 520	└ 927*	09 18 520	└ 917*	09 18 520	└ 907*	
26		09 18 526	└ 927*	09 18 526	└ 917*	09 18 526	└ 907*	
30		09 18 530	└ 927*	09 18 530	└ 917*	09 18 530	└ 907*	
34		09 18 534	└ 927*	09 18 534	└ 917*	09 18 534	└ 907*	
40		09 18 540	└ 927*	09 18 540	└ 917*	09 18 540	└ 907*	
50		09 18 550	└ 927*	09 18 550	└ 917*	09 18 550	└ 907*	
60		09 18 560	└ 927*	09 18 560	└ 917*	09 18 560	└ 907*	
64		09 18 564	└ 927*	09 18 564	└ 917*	09 18 564	└ 907*	

SEK

\* Not normally kept in stock  
 For accessories see page 08.22  
 For dimensions see page 08.21

For performance level 3 please specify digit  
 For performance level 2 please specify digit  
 S4 > 0.76 µm Au (30 µ inch) or equivalent PdNi

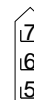
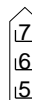

Number of contacts

# 6-64

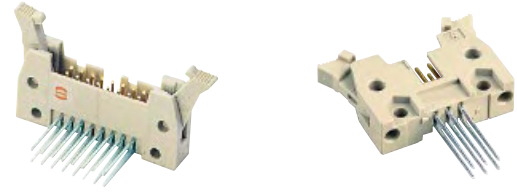

Male header with wrap posts

Identification

Drawing

Dimensions in mm

Male header

No. of contacts	A	B	C	D	E	F	G
6	26.9	16.76	22.86	12.45	2.54 x 2 = 5.08	36.9	40.3
10	32.0	21.84	27.94	17.53	2.54 x 4 = 10.16	42.0	45.4
14	37.1	26.92	33.02	22.61	2.54 x 6 = 15.24	47.1	50.4
16	39.6	29.46	35.56	25.15	2.54 x 7 = 17.78	49.6	53.0
20	44.7	34.54	40.64	30.23	2.54 x 9 = 22.86	54.7	58.1
26	52.3	42.16	48.26	37.85	2.54 x 12 = 30.48	62.3	65.7
30	57.7	47.24	53.43	43.83	2.54 x 14 = 35.56	68.2	68.6
34	62.5	52.32	58.42	48.01	2.54 x 16 = 40.64	72.5	75.8
40	70.1	59.94	66.04	55.63	2.54 x 19 = 48.26	80.1	83.5
50	82.8	72.64	78.74	68.33	2.54 x 24 = 60.96	92.8	96.2
60	95.5	85.34	91.44	81.03	2.54 x 29 = 73.66	105.5	108.9
64	100.6	90.42	96.52	86.11	2.54 x 31 = 78.74	110.6	113.9

**Long levers**

for use with female connector with strain relief clamp

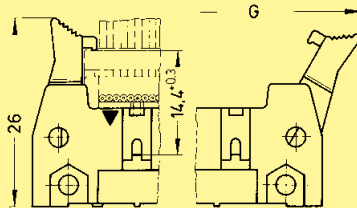

**Short levers**

for use with female connector without strain relief clamp

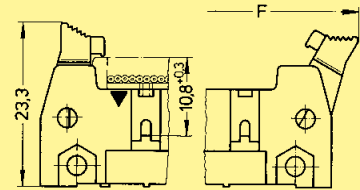

**Angled versions**

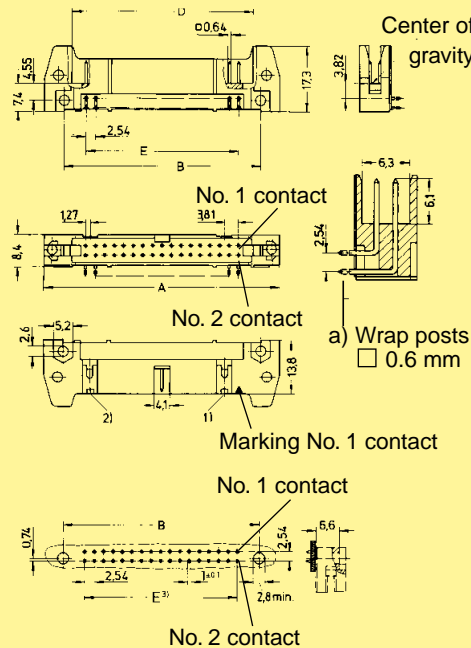

**Straight versions**

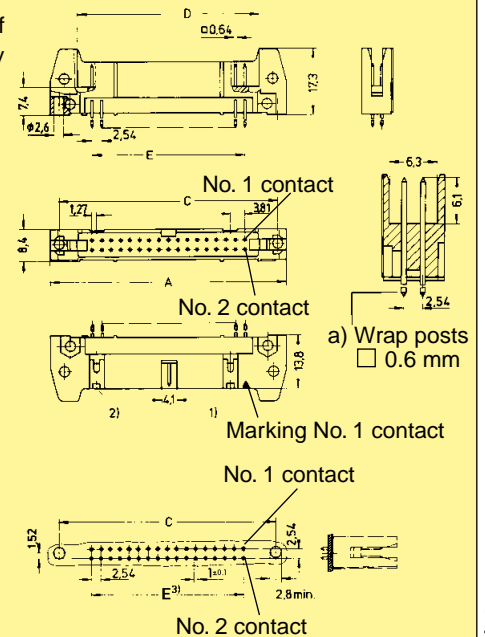

Board drillings

For accessories see page 08.22

<sup>1)</sup> No polarization slot for 6, 10 or 14 way male header

<sup>2)</sup> No polarization slot for 6 way male header  
<sup>3)</sup> Pitch tolerance: ± 0.1

Accessories

Identification	Part No.	Drawing	Dimensions in mm
<p>Polarization key</p> <p>1) Part No. comprises 2 keys</p>	09 18 500 9902 <sup>1)</sup>		
<p>Locking lever (snaps into place, can be fitted whenever required)</p> <p>2) Order 2 per male header</p>	<p>Long: 09 18 000 9903<sup>2)</sup></p> <p>Short: 09 18 000 9904<sup>2)</sup></p>	<p>Long</p> <p>Short</p> <p>For use with female connector <u>with</u> strain relief clamp</p> <p>For use with female connector <u>without</u> strain relief clamp</p>	
<p>Fixing screws for 1.6 mm P.C. board</p> <p>3) Part No. comprises 50 pieces</p>	09 18 000 9906 <sup>3)</sup>		<p>For connectors with part numbers 09 18 5xx x9xx: screwing torque 0.2 Nm</p> <p>09 19 5xx x9xx: screwing torque 0.4 – 0.5 Nm</p> <p>Screw material: Steel (Inox A2)</p> <p>Plating: Nickel</p>
<p>Coding system with loss of contact</p> <p>4) Part No. comprises 6 code pins</p>	<p>Code pin 09 18 000 9901<sup>4)</sup></p> <p>Removal tool for male contacts 09 99 000 0133</p>	<p>To avoid cross-plugging adjacent connectors a coding system is required. A code pin is inserted into the appropriate cavity in the female connector. The corresponding male contact is removed by a special removal tool.</p>	

SEK

Number of contacts 6, 10, 14, 16, 20, 26, 30, 34, 40, 50, 60, 64

Approvals IEC 60603-13  
DIN EN 60603-13  
D 2632  
BT 224  
NFC 93-428 (HE 10)  
UL recognized: E102079



Pitch 2.54 mm [0.100"]

Working current 1 A

Working voltage 320 V for pollution degree 1

Test voltage  $U_{r.m.s.}$  1 kV

Contact resistance  $\leq 20 \text{ m}\Omega$   
Insulation resistance  $\geq 10^9 \Omega$

Temperature range -55 °C ... +125 °C  
The maximum temperature includes heating of contacts and ambient temperature

Terminations IDC flat cable  
1.27 mm [0.050"] pitch:  
AWG 26/7 – AWG 28/7

Materials Moulding Thermoplastic resin (PBT)  
UL 94-V0

Contact surface Contact zone gold-plated according to performance level<sup>1)</sup>

### Current carrying capacity

The current carrying capacity is limited by maximum temperature of materials for inserts and contacts including terminals. The current capacity-curve is valid for continuous, not interrupted current-loaded contacts of connectors when simultaneous power on all contacts is given, without exceeding the maximum temperature.

Control and test procedures according to DIN IEC 60512.

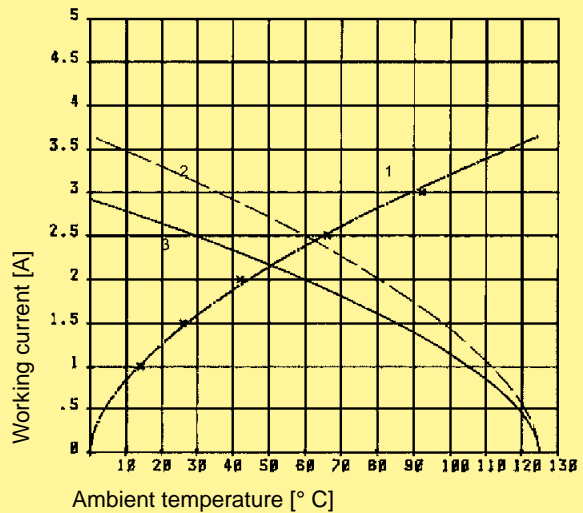

Example: 50 way connector

- ① Temperature rise
- ② Derating
- ③ Derating curve at  $I_{max} \times 0.8$  (IEC 60512-2)

### Insertion and withdrawal forces

Number of contacts	Maximum force [N]	
	Performance level 1 and 2	Performance level 3
6	12	18
10	20	30
14	28	42
16	32	48
20	40	60
26	52	78
30	60	90
34	68	102
40	80	120
50	100	150
60	120	180
64	128	192

<sup>1)</sup> Performance level 3 as per IEC 60603-13,  $\geq 50$  mating cycles, no gas test  
Performance level 2 as per IEC 60603-13,  $\geq 250$  mating cycles, 4 days gas test  
S4, plating  $> 0.76 \mu\text{m Au}$  (30  $\mu$  inch) or equivalent PdNi



Number of contacts

# 6-64



Female connector

Identification      No. of contacts      Part No.      Drawing      Dimensions in mm

Female connector  
with central  
polarization

without  
strain relief clamp

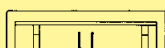

		open end cover	closed end cover
6	09 18 506	┌ 803	09 18 506 ┌ 804
10	09 18 510	┌ 803	09 18 510 ┌ 804
14	09 18 514	┌ 803	09 18 514 ┌ 804
16	09 18 516	┌ 803	09 18 516 ┌ 804
20	09 18 520	┌ 803	09 18 520 ┌ 804
26	09 18 526	┌ 803	09 18 526 ┌ 804
30	09 18 530	┌ 803	09 18 530 ┌ 804
34	09 18 534	┌ 803	09 18 534 ┌ 804
40	09 18 540	┌ 803	09 18 540 ┌ 804
50	09 18 550	┌ 803	09 18 550 ┌ 804
60	09 18 560	┌ 803	09 18 560 ┌ 804
64	09 18 564	┌ 803	09 18 564 ┌ 804

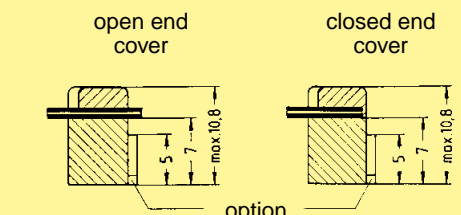

without  
strain relief clamp  
with bulk packaging

6	09 18 506	┌ 803 58U <sup>2)</sup>	
10	09 18 510	┌ 803 58U <sup>2)</sup>	
14	09 18 514	┌ 803 58U <sup>2)</sup>	
16	09 18 516	┌ 803 58U <sup>2)</sup>	
20	09 18 520	┌ 803 58U <sup>2)</sup>	
26	09 18 526	┌ 803 58U <sup>2)</sup>	
30	09 18 530	┌ 803 58U <sup>2)</sup>	
34	09 18 534	┌ 803 58U <sup>3)</sup>	
40	09 18 540	┌ 803 58U <sup>3)</sup>	

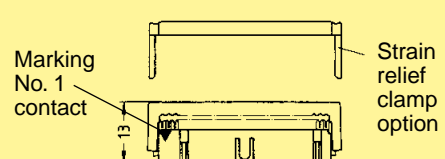
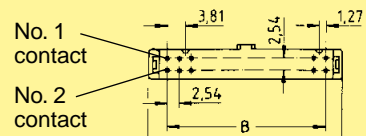

with  
strain relief clamp



6	09 18 506	┌ 813	09 18 506 ┌ 814*
10	09 18 510	┌ 813	09 18 510 ┌ 814*
14	09 18 514	┌ 813	09 18 514 ┌ 814*
16	09 18 516	┌ 813	09 18 516 ┌ 814*
20	09 18 520	┌ 813	09 18 520 ┌ 814*
26	09 18 526	┌ 813	09 18 526 ┌ 814*
30	09 18 530	┌ 813	09 18 530 ┌ 814*
34	09 18 534	┌ 813	09 18 534 ┌ 814*
40	09 18 540	┌ 813	09 18 540 ┌ 814*
50	09 18 550	┌ 813	09 18 550 ┌ 814*
60	09 18 560	┌ 813	09 18 560 ┌ 814*
64	09 18 564	┌ 813	09 18 564 ┌ 814*

No. of contacts	6	10	14	16	20	26
A	12.20	17.30	22.40	24.90	30.00	37.60
B	5.08	10.16	15.24	17.78	22.86	30.48

No. of contacts	30	34	40	50	60	64
A	42.70	47.80	55.40	68.10	80.80	85.90
B	35.56	40.64	48.26	60.96	73.66	78.74

with  
strain relief clamp  
with bulk packaging

6	09 18 506	┌ 813 58U <sup>3)</sup>	
10	09 18 510	┌ 813 58U <sup>3)</sup>	
14	09 18 514	┌ 813 58U <sup>4)</sup>	
16	09 18 516	┌ 813 58U <sup>4)</sup>	
20	09 18 520	┌ 813 58U <sup>5)</sup>	
26	09 18 526	┌ 813 58U <sup>6)</sup>	
30	09 18 530	┌ 813 58U <sup>5)</sup>	
34	09 18 534	┌ 813 58U <sup>7)</sup>	
40	09 18 540	┌ 813 58U <sup>7)</sup>	

- 3) Packaging unit (PU) 3,000 pieces
- 4) PU 2,500 pieces
- 5) PU 2,000 pieces
- 6) PU 1,500 pieces
- 7) PU 1,000 pieces

<sup>1)</sup> Pitch tolerance: ± 0.1  
\* Not normally kept in stock

Number of contacts

# 6-64



## Strain relief clamp/Locking lever

Identification      No. of contacts      Part No.      Drawing      Dimensions in mm

### Strain relief clamp

6	09 18 506 9002
10	09 18 510 9002
14	09 18 514 9002
16	09 18 516 9002
20	09 18 520 9002
26	09 18 526 9002
30	09 18 530 9002
34	09 18 534 9002
40	09 18 540 9002
50	09 18 550 9002
60	09 18 560 9002
64	09 18 564 9002

No. of contacts	A
6	12.2
10	17.3
14	22.4
16	24.9
20	30.0
26	37.6
30	35.56
34	47.8
40	55.4
50	68.1
60	80.8
64	85.9

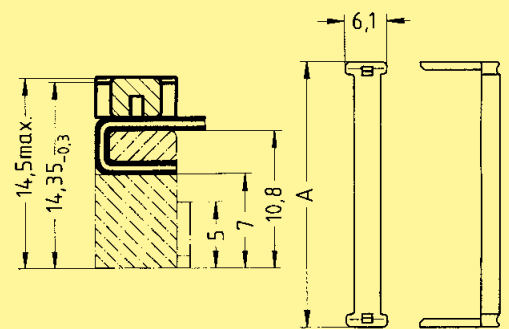

with bulk packaging

6	09 18 506 9002 58U <sup>3)</sup>
10	09 18 510 9002 58U <sup>3)</sup>
14	09 18 514 9002 58U <sup>3)</sup>
16	09 18 516 9002 58U <sup>3)</sup>
20	09 18 520 9002 58U <sup>3)</sup>
26	09 18 526 9002 58U <sup>3)</sup>
30	09 18 530 9002 58U <sup>3)</sup>
34	09 18 534 9002 58U <sup>4)</sup>
40	09 18 540 9002 58U <sup>4)</sup>

<sup>3)</sup> Packaging unit  
5,000 pieces  
<sup>4)</sup> Packaging unit  
3,000 pieces

### Locking lever for female connector

Only in conjunction with low-profile male header and strain relief

09 18 000 9905<sup>1)5)</sup>  
09 18 000 9905 58U<sup>1)6)</sup>

<sup>5)</sup> Packaging unit  
100 pieces  
<sup>6)</sup> Packaging unit  
5,000 pieces

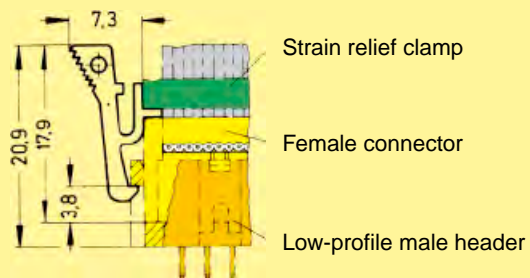

When the security of latching is required and space is a premium, these locking levers can be fitted onto the strain relief of the HARTING female connector. This can then be used in conjunction with male low-profile headers (see pages 08.16 and 08.17).

### Coding system with loss of contact

Code pin

09 18 000 9901<sup>2)</sup>

Removal tool for male contacts

09 99 000 0133

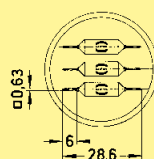

To avoid cross-plugging adjacent connectors a coding system is required. A code pin is inserted into the appropriate cavity in the female connector. The corresponding male contact is removed by a special removal tool.



<sup>1)</sup> Order 2 per female connector  
<sup>2)</sup> Part No. comprises 6 code pins

Number of contacts 4, 6, 8, 10, 14, 16, 20, 24, 26, 30, 34, 40, 50, 60, 64

Pitch  
On pcb side: 2.54 mm [0.100"]  
On cable side: 1.27 mm [0.050"]

Working current 1 A

Test voltage  $U_{r.m.s.}$  1 kV AC – 1 minute

Contact resistance 35 m $\Omega$  max. mated  
Insulation resistance  $\geq 10^9 \Omega$

Temperature range -55 °C ... +105 °C  
The maximum temperature includes heating of contacts and ambient temperature

Terminations  
Solder pins:  
0.635 mm x 0.3 mm  
Dimensions for pcb hole:  
Standard version:  $\varnothing 0.9^{\pm 0.10}$  mm  
Kinked version:  $\varnothing 1.0^{\pm 0.05}$  mm  
Diagonal: 0.71 mm  
IDC flat cable  
1.27 mm [0.050"] pitch: AWG 28/7

Materials  
Moulding Thermoplastic resin (PBT)  
UL 94-V0

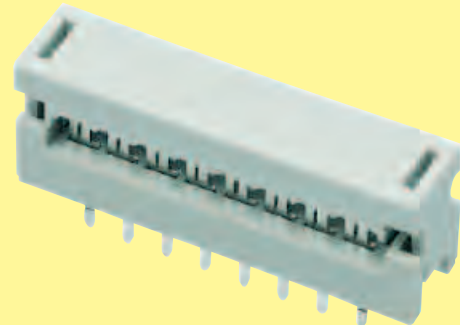
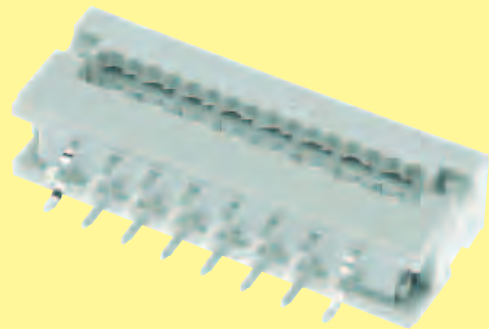

Number of contacts

4-64

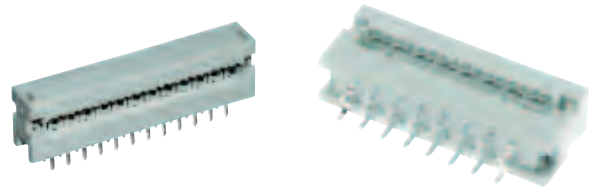

Pcb transition connector, 2 rows, low-profile with 5.5 mm height

Identification      No. of contacts      Part No.      Drawing      Dimensions in mm

**Pcb transition connector**  
2 rows  
Standard low-profile version

No. of contacts	Part No.
4	09 18 104 9622
6	09 18 106 9622
8	09 18 108 9622
10	09 18 110 9622
14	09 18 114 9622
16	09 18 116 9622
20	09 18 120 9622
24	09 18 124 9622
26	09 18 126 9622
30	09 18 130 9622
34	09 18 134 9622
40	09 18 140 9622
50	09 18 150 9622
60	09 18 160 9622
64	09 18 164 9622

No. of contacts	A±0.38	B±0.10
4	10.38	2.54 x 1 = 2.54
6	12.92	2.54 x 2 = 5.08
8	15.46	2.54 x 3 = 7.62
10	18.00	2.54 x 4 = 10.16
14	23.08	2.54 x 6 = 15.24
16	25.62	2.54 x 7 = 17.78
20	30.74	2.54 x 9 = 22.86
24	35.78	2.54 x 11 = 27.94
26	38.32	2.54 x 12 = 30.48
30	43.40	2.54 x 14 = 35.56
34	48.48	2.54 x 16 = 40.64
40	56.10	2.54 x 19 = 48.26
50	68.80	2.54 x 24 = 60.96
60	81.50	2.54 x 29 = 73.66
64	86.58	2.54 x 31 = 78.74

**Pcb transition connector**  
2 rows  
Kinked low-profile version  
2 kinked pins at each extremity

No. of contacts	Part No.
4	09 18 104 9422
6	09 18 106 9422
8	09 18 108 9422
10	09 18 110 9422
14	09 18 114 9422
16	09 18 116 9422
20	09 18 120 9422
24	09 18 124 9422
26	09 18 126 9422
30	09 18 130 9422
34	09 18 134 9422
40	09 18 140 9422
50	09 18 150 9422
60	09 18 160 9422
64	09 18 164 9422

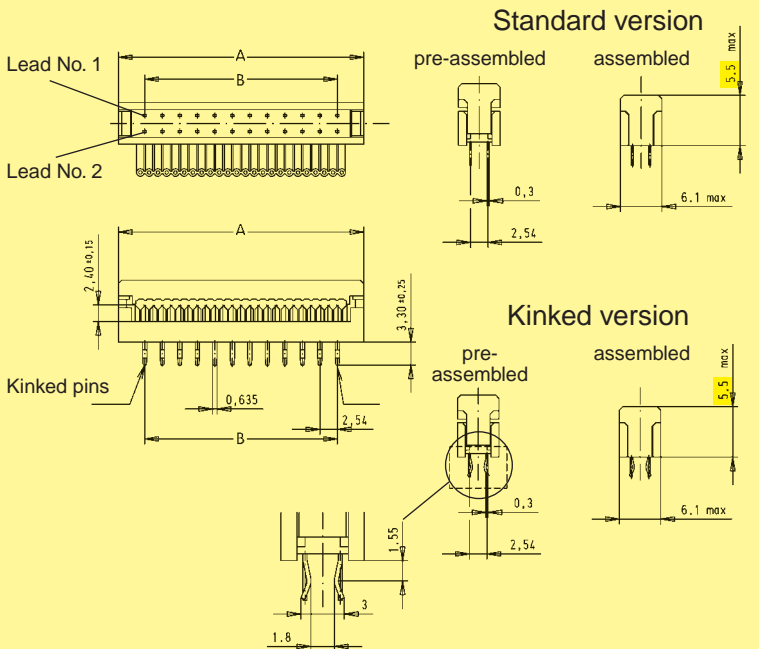

Board drillings

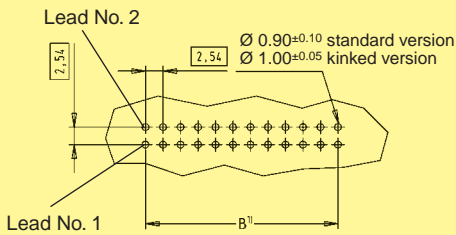

1) Pitch tolerance: ± 0.05

SEK

Number of contacts\* 10, 16, 20, 26, 34, 40, 50

Pitch  
On pcb side: 2.54 mm [0.100"]  
On cable side: 1.27 mm [0.050"]

Working current 1 A

Test voltage  $U_{r.m.s.}$  500 V

Contact resistance  $\leq 20 \text{ m}\Omega$   
Insulation resistance  $\geq 10^{12} \Omega$

Temperature range -40 °C ... +125 °C  
The maximum temperature includes heating of contacts and ambient temperature

Terminations  
Solder pins  
0.45 mm x 0.35 mm  
for pcb hole  $\varnothing$  0.8 mm  
Diagonal: 0.58 mm  
IDC flat cable  
1.27 mm [0.050"] pitch:  
AWG 28/7

Materials  
Moulding Thermoplastic resin (PC)  
UL 94-V0

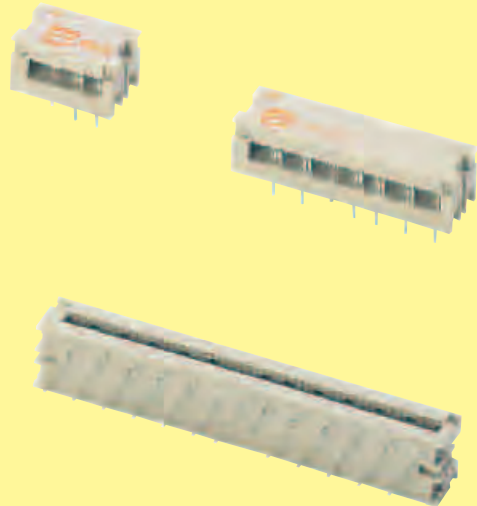

Number of contacts

# 10-50

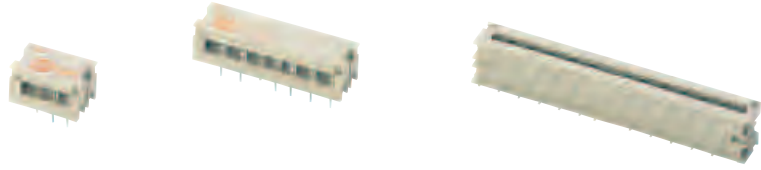

Pcb transition connector, 4 rows

Identification      No. of contacts      Part No.      Drawing      Dimensions in mm

Pcb transition connector  
4 rows

10	09 19 010 9643*
16	09 19 016 9643*
20	09 19 020 9643*
26	09 19 026 9643*
34	09 19 034 9643*
40	09 19 040 9643*
50	09 19 050 9643*

No. of contacts	A	B
10	17.78	1.27 x 9 = 11.43
16	25.40	1.27 x 15 = 19.05
20	30.48	1.27 x 19 = 24.13
26	38.10	1.27 x 25 = 31.75
34	48.26	1.27 x 33 = 41.91
40	55.88	1.27 x 39 = 49.53
50	68.58	1.27 x 49 = 62.23

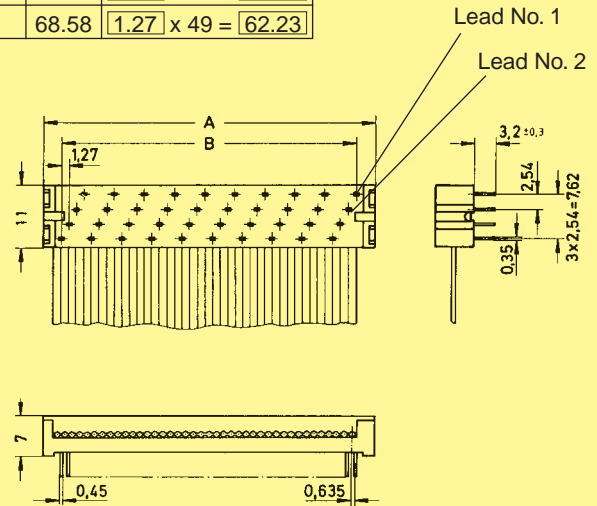

Board drillings

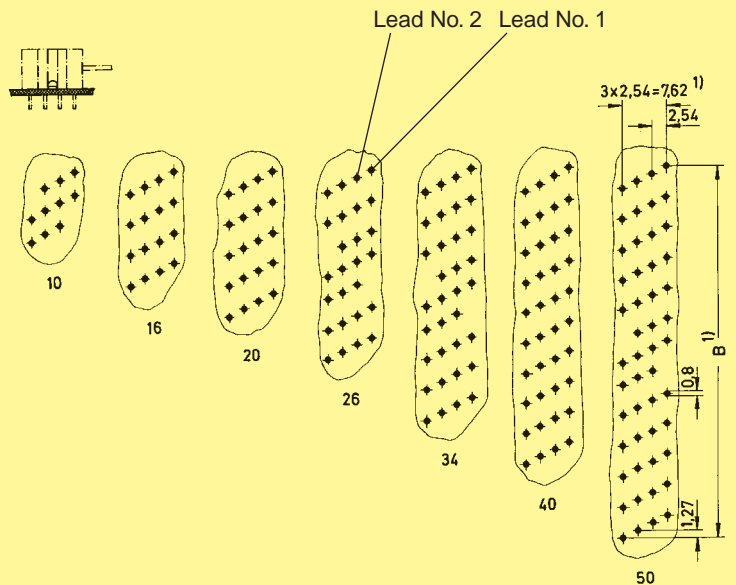

\* Not normally kept in stock.  
1) Pitch tolerance: ± 0.1

SEK

Number of contacts*	14, 16, 24, 28, 40
Pitch	On pcb side: 2.54 mm [0.100"] On cable side: 1.27 mm [0.050"]
Working current	1 A
Test voltage $U_{r.m.s.}$	500 V
Contact resistance	$\leq 20 \text{ m}\Omega$
Insulation resistance	$\geq 10^{12} \Omega$
Temperature range	-40 °C ... +125 °C The maximum temperature includes heating of contacts and ambient temperature
Terminations	Solder pins 0.45 mm x 0.35 mm for pcb hole $\varnothing$ 0.8 mm Diagonal: 0.58 mm IDC flat cable 1.27 mm [0.050"] pitch: AWG 28/7
Materials Moulding	Thermoplastic resin (PC) UL 94-V0

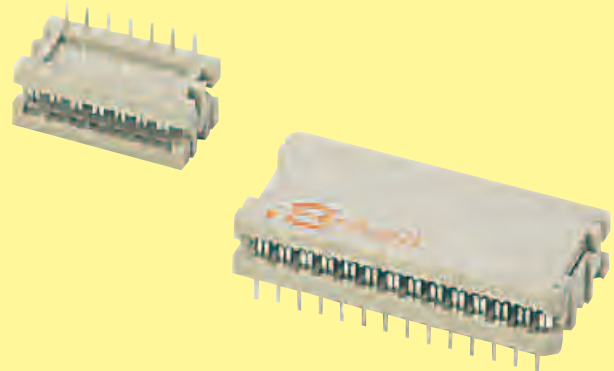

Number of contacts

# 14-40

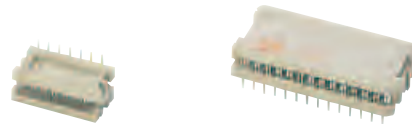

DIP connector for IC base or for soldering into pcb

Identification      No. of contacts      Part No.      Drawing      Dimensions in mm

DIP connector

14	09 17 014 9622*
16	09 17 016 9622*
24	09 17 024 9622*
28	09 17 028 9622*
40	09 17 040 9622*

No. of contacts	A	B	C	D
14	20.5	2.54 x 6 = 15.24	11	7.62
16	23.0	2.54 x 7 = 17.78	11	7.62
24	33.0	2.54 x 11 = 27.94	18.7	15.24
28	38.1	2.54 x 13 = 33.02	18.7	15.24
40	53.3	2.54 x 19 = 48.26	18.7	15.24

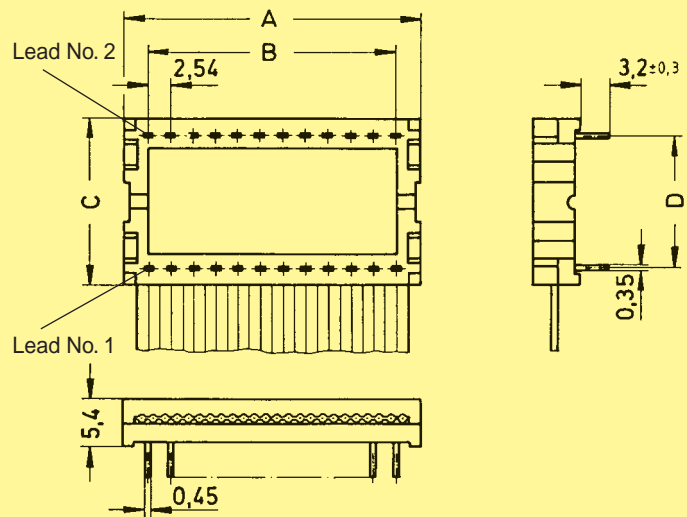

Board drillings

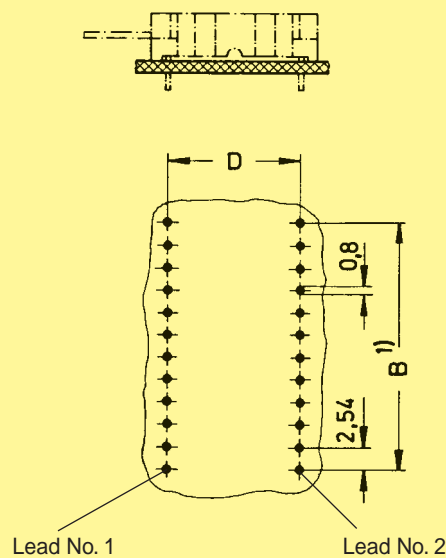

\* Not normally kept in stock  
 1) Pitch tolerance: ± 0.1



Number of contacts	64
Pitch	2.54 mm [0.100"]
Working current	1 A max.
Clearance Creepage	$\geq 1.2$ mm $\geq 1.2$ mm
Working voltage	according to the safety regulations of the equipment
<p>The working voltage also depends on the clearance and creepage dimensions of the pcb itself, and the associated wiring</p>	
Test voltage $U_{r.m.s.}$	1 kV
Contact resistance	$\leq 20$ m $\Omega$
Insulation resistance	$\geq 10^{12}$ $\Omega$
Temperature range	-55 °C ... +125 °C
<p>The maximum temperature includes heating of contacts and ambient temperature</p>	
Termination	
Female connector	Insulation displacement: AWG 28/7
Insertion and withdrawal force	$\leq 60$ N
Materials	
Moulding	Thermoplastic resin, glass-fibre filled, UL 94-V0
Contacts	Copper alloy
Contact surface	
Contact zone	selectively plated according to performance level

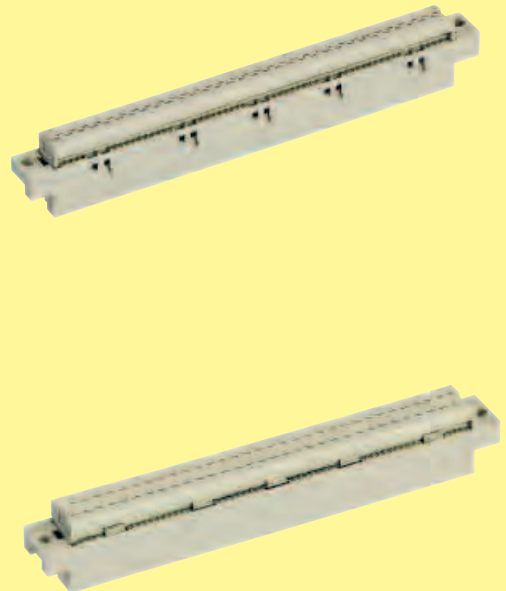

SEK

Number of contacts

64

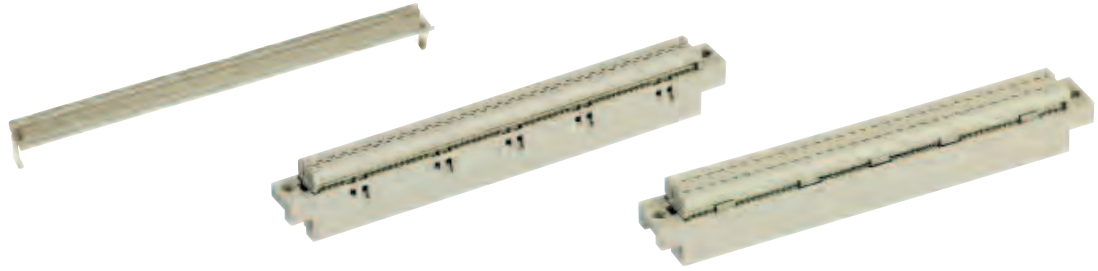

Female connectors for insulation displacement

Identification	No. of contacts	Part No.	Drawing	Dimensions in mm
----------------	-----------------	----------	---------	------------------

Female connector for insulation displacement

Type B

64

performance level 2

09 02 264 6828

performance level 3

09 02 264 7828

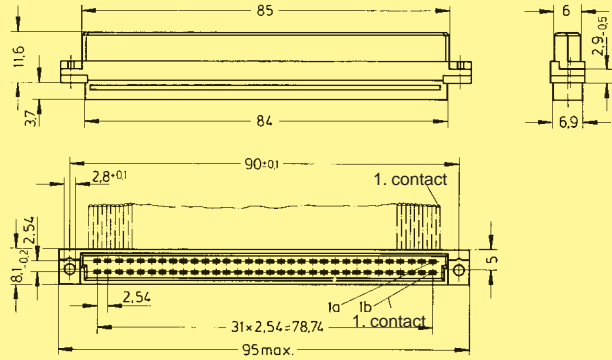

Lead number 1 of flat cable on contact 1 b

Contact arrangement View from termination side

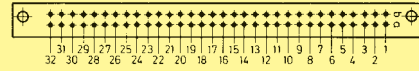

Type C

64

performance level 2

09 03 264 6828

09 03 764 6828<sup>c)</sup>

performance level 3

09 03 264 7828

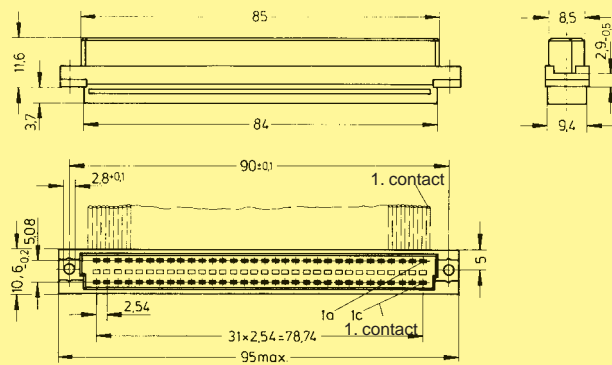

Lead number 1 of flat cable on contact 1 c

Contact arrangement View from termination side

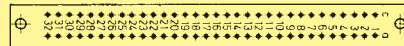

Mateable with 3-row male connector Type C.  
No female contact in middle row.

Panel cut out

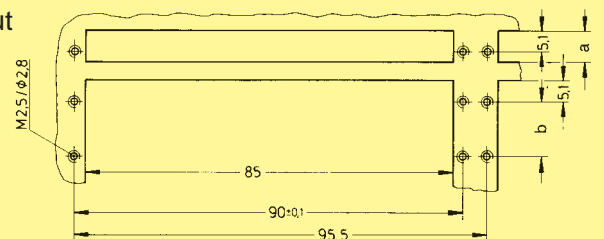

	a	b
Type B	8.3	10.16
Type C	10.8	12.7

Strain relief for types B and C

09 03 000 9940

Number of contacts 10, 14, 16, 20, 26, 34, 40, 50, 60, 64

Contact arrangement straight

Contact length 4.5 mm

Approvals IEC 60603-13

Design acc. to D 2632  
BT 224  
BS 9525  
NFC 93-428 (HE 10)

Pitch 2.54 mm [0.100"]

Working current 1 A

Working voltage 350 V DC or AC peak

Test voltage  $U_{r.m.s.}$  1 kV

Contact resistance  $\leq 20 \text{ m}\Omega$   
Insulation resistance  $\geq 10^9 \Omega$

Temperature range  $-55 \text{ }^\circ\text{C} \dots +125 \text{ }^\circ\text{C}$   
The maximum temperature includes heating of contacts and ambient temperature

Materials  
Moulding PBT  
UL 94-V0  
Contacts Phosphor bronze

Contact surface  
Contact zone gold-plated according to performance level<sup>1)</sup>

### Terminations Recommended PCB through holes

<i>Tin-lead plated PCB</i>	Hole	$1.15^{\pm 0.025}$
	Cu	min. 25 $\mu\text{m}$
	Sn	max. 15 $\mu\text{m}$
	Plated hole	0.94-1.09 mm
<i>Chemical tin-plated PCB</i>	Hole	$1.15^{\pm 0.025}$
	Cu	min. 25 $\mu\text{m}$
	Sn	min. 0.8 $\mu\text{m}$
	Plated hole	1.00-1.10 mm
<i>Au / Ni plated PCB</i>	Hole	$1.15^{\pm 0.025}$
	Cu	min. 25 $\mu\text{m}$
	Ni	3-7 $\mu\text{m}$
	Au	0.05-0.12 $\mu\text{m}$
	Plated hole	1.00-1.10 mm
<i>Silver plated PCB</i>	Hole	$1.15^{\pm 0.025}$
	Cu	min. 25 $\mu\text{m}$
	Ag	0.1-0.3 $\mu\text{m}$
	Plated hole	1.00-1.10 mm
<i>OSP copper plated PCB</i>	Hole	$1.15^{\pm 0.025}$
	Cu	min. 25 $\mu\text{m}$
	Plated hole	1.00-1.10 mm
PCB board thickness: $\geq 1.6 \text{ mm}$		

### Insertion and withdrawal forces

Number of contacts	Maximum force [N]
	Performance level 1
10	20
14	28
16	32
20	40
26	52
34	68
40	80
50	100
60	120
64	128

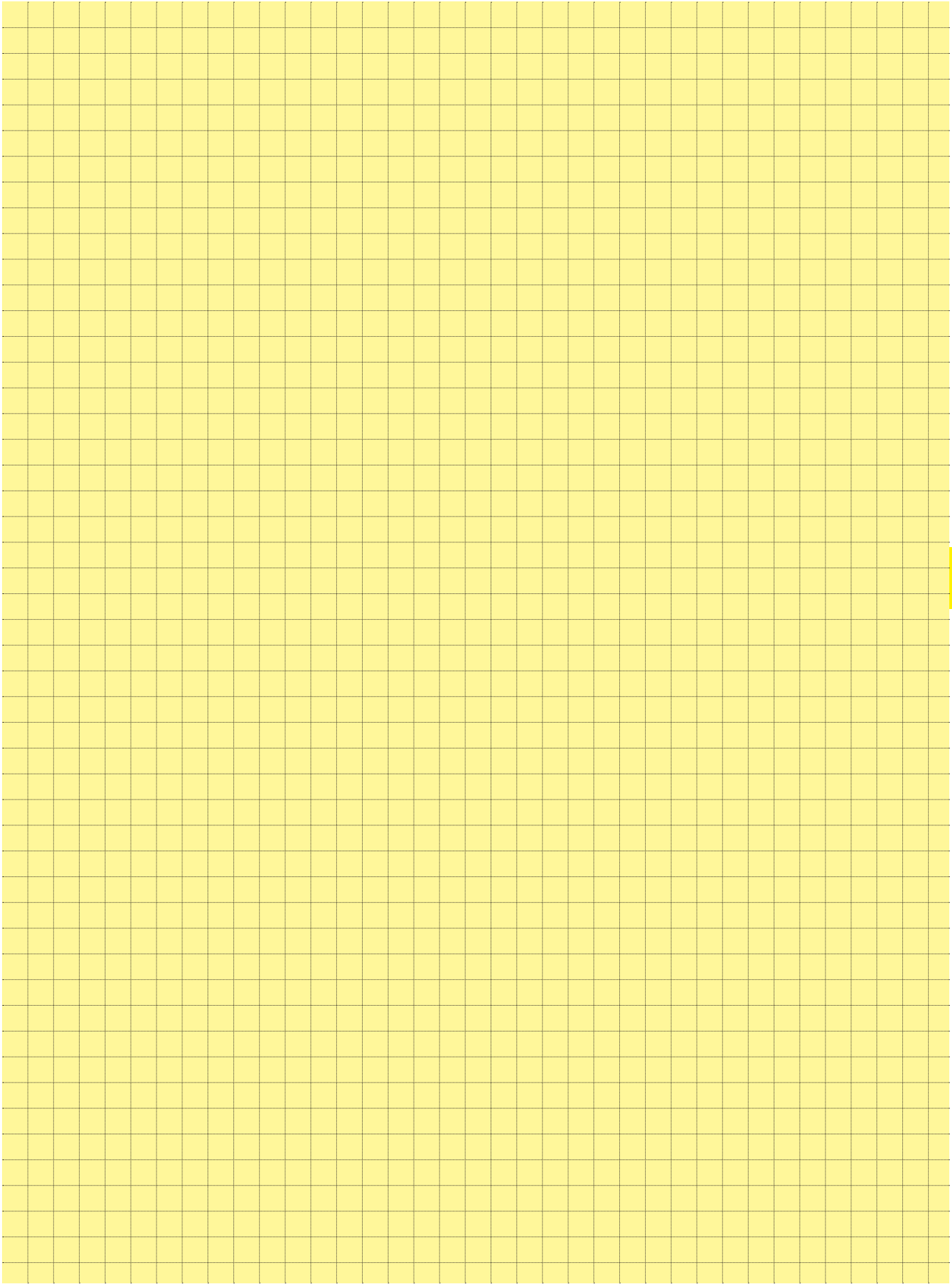

Number of contacts

# 10-64

Male header,  
straight press-in pins

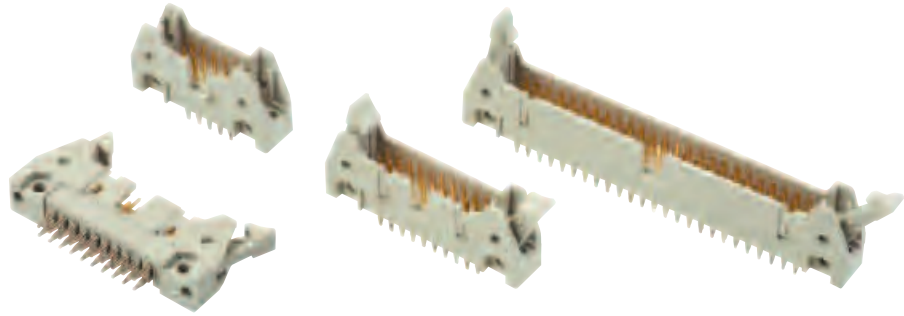

Identification	No. of contacts	Part No.		
		Without levers	With short levers	With long levers
Male header with straight press-in terminations Length: 4.5 mm	10	09 18 510 5929	09 18 510 5919	09 18 510 5909
	14	09 18 514 5929	09 18 514 5919	09 18 514 5909
	16	09 18 516 5929	09 18 516 5919	09 18 516 5909
	20	09 18 520 5929	09 18 520 5919	09 18 520 5909
	26	09 18 526 5929	09 18 526 5919	09 18 526 5909
	34	09 18 534 5929	09 18 534 5919	09 18 534 5909
	40	09 18 540 5929	09 18 540 5919	09 18 540 5909
	50	09 18 550 5929	09 18 550 5919	09 18 550 5909
	60	09 18 560 5929	09 18 560 5919	09 18 560 5909
	64	09 18 564 5929	09 18 564 5919	09 18 564 5909

SEK

Number of contacts

# 10-64

Male header,  
straight press-in pins

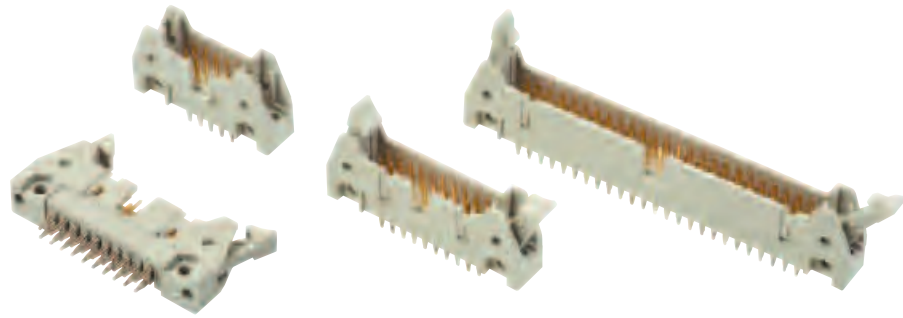

Identification

Drawing

Dimensions in mm

Male header

No. of contacts	A	C	D	E	F	G
10	32.11	21.84	17.91	2.54 x 4 = 10.16	45.11	50.11
14	37.19	26.92	22.99	2.54 x 6 = 15.24	50.19	55.19
16	39.73	29.46	25.53	2.54 x 7 = 17.78	52.73	57.73
20	44.81	34.54	30.61	2.54 x 9 = 22.86	57.81	62.81
26	52.43	42.16	38.23	2.54 x 12 = 30.48	65.43	70.43
34	62.59	52.32	48.39	2.54 x 16 = 40.64	75.59	80.59
40	70.21	59.94	56.01	2.54 x 19 = 48.26	83.21	88.21
50	82.91	72.64	68.71	2.54 x 24 = 60.96	95.91	100.91
60	95.61	85.34	81.41	2.54 x 29 = 73.66	108.61	113.61
64	100.69	90.42	86.49	2.54 x 31 = 78.74	113.69	118.69

Marking  
No. 1 contact

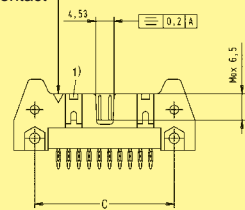

Short levers

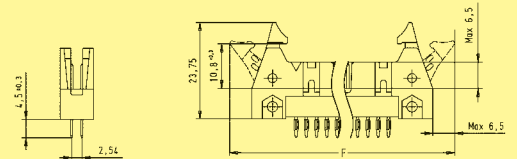

Long levers

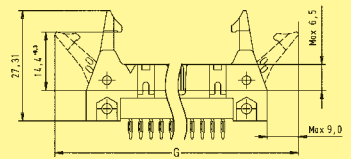
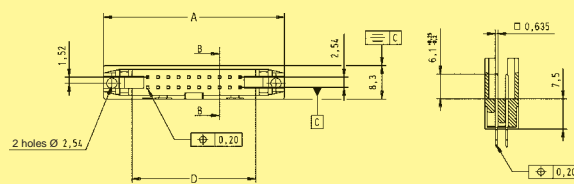

Section B-B

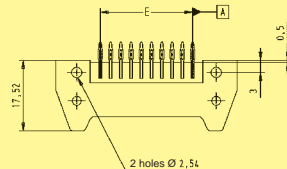

Board drillings

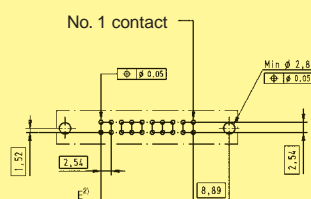

1) No polarization slot for 10 or 14 way male header

2) Pitch tolerance: ± 0.1

Number of contacts 6, 10, 14, 16, 20, 26, 34, 40, 50, 60, 64

Contact arrangement straight

Contact length 5.5 mm

Approvals IEC 60603-13  
DIN EN 60603-13  
D 2632  
BT 224  
NFC 93-428 (HE 10)  
UL recognized: E102079



Pitch 2.54 mm [0.100"]

Working current 1 A

Test voltage  $U_{r.m.s.}$  1 kV

Contact resistance  $\leq 20 \text{ m}\Omega$   
Insulation resistance  $\geq 10^9 \Omega$

Temperature range -55 °C ... +105 °C  
The maximum temperature includes heating of contacts and ambient temperature

#### Press-in

Diameter of pcb plated through holes  $\varnothing 1.0^{+0.09}_{-0.06} \text{ mm}$

Recommended pcb holes for press-in process  
Hole:  $\varnothing 1.12 - 1.15 \text{ mm}$   
Cu : 25 – 75  $\mu\text{m}$   
Sn : 5 – 15  $\mu\text{m}$

Pcb thickness 1.6 – 3.2 mm

#### Materials

Moulding Thermoplastic resin (PBT)  
UL 94-V0

#### Contact surface

Contact zone gold-plated according to performance level<sup>1)</sup>

#### Insertion and withdrawal forces

Number of contacts	Maximum force [N]	
	Performance level 1 and 2	Performance level 3
6	12	18
10	20	30
14	28	42
16	32	48
20	40	60
26	52	78
34	68	102
40	80	120
50	100	150
60	120	180
64	128	192

<sup>1)</sup> Performance level 3 as per IEC 60603-13,  $\geq 50$  mating cycles, no gas test  
Performance level 2 as per IEC 60603-13,  $\geq 250$  mating cycles, 4 days gas test  
S4, plating > 0.76  $\mu\text{m}$  Au (30  $\mu$  inch) or equivalent PdNi

Number of contacts

# 6-64

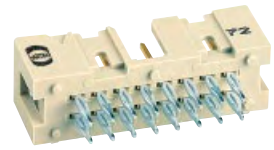

Low-profile male header, straight press-in pins

Identification      No. of contacts      Part No.      Drawing      Dimensions in mm

Low-profile male header with straight press-in terminations  
Length: 5.5 mm

No. of contacts	Part No.	Drawing
6	09 18 506	329
10	09 18 510	329
14	09 18 514	329
16	09 18 516	329
20	09 18 520	329
26	09 18 526	329
34	09 18 534	329
40	09 18 540	329
50	09 18 550	329
60	09 18 560	329
64	09 18 564	329

No. of contacts	A	B	E
6	15.2	12.78	2.54 x 2 = 5.08
10	20.3	17.86	2.54 x 4 = 10.16
14	25.4	22.94	2.54 x 6 = 15.24
16	27.9	25.48	2.54 x 7 = 17.78
20	33.0	30.56	2.54 x 9 = 22.86
26	40.6	38.18	2.54 x 12 = 30.48
34	50.8	48.34	2.54 x 16 = 40.64
40	58.4	55.96	2.54 x 19 = 48.26
50	71.3	68.66	2.54 x 24 = 60.96
60	84.0	81.36	2.54 x 29 = 73.66
64	89.1	86.44	2.54 x 31 = 78.74

Board drillings

Marking No. 1 contact

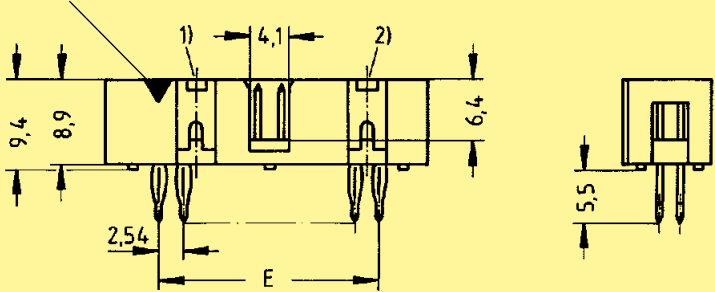

No. 2 contact

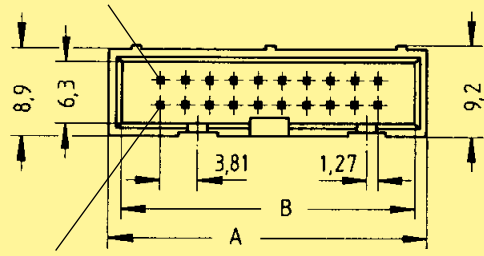

No. 1 contact

No. 2 contact

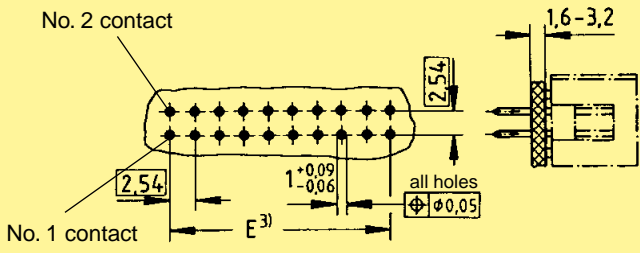

For Performance Level 3 please specify digit  
For Performance Level 2 please specify digit  
S4 > 0.76 μm Au (30 μ inch) or equivalent PdNi



Not normally kept in stock

- 1) No polarization slot for 6, 10 or 14 way
- 2) No polarization slot for 6 way
- 3) Pitch tolerance: ± 0.1



Number of contacts 6, 10, 14, 16, 20, 26, 30, 34, 40, 50, 60, 64

Contact arrangement straight, angled

Contact length 2.9 mm

Approvals IEC 60 603-13  
DIN EN 60 603-13  
D 2632  
BT 224  
NFC 93-428 (HE 10)

Pitch 2.54 mm [0.100"]

Working current 1 A

Working voltage 500 V  
for pollution degree 1

Test voltage  $U_{r.m.s.}$  1 kV

Contact resistance  $\leq 20 \text{ m}\Omega$   
Insulation resistance  $\geq 10^9 \Omega$

Temperature range -55 °C ... +125 °C  
during reflow soldering max. + 240 °C for 60 s  
The higher temperature limit includes the local ambient and heating effect of the contacts under load

Terminations For pcb hole  $\varnothing 1 \pm 0.1 \text{ mm}$   
DIN IEC 52 141  
Diagonal: 0.79 mm

Materials  
Moulding Thermoplastic resin (PCT)  
UL 94-V0

Contact surface  
Contact zone gold-plated according to performance level<sup>1)</sup>

#### Options on request

Colour of connectors black

For pick & place process Tape & Reel packaging  
with/without vacuum plate  
Tube packaging  
with/without vacuum plate



#### Insertion and withdrawal forces

Number of contacts	Maximum force [N]	
	Performance level 1 and 2	Performance level 3
6	12	18
10	20	30
14	28	42
16	32	48
20	40	60
26	52	78
30	60	90
34	68	102
40	80	120
50	100	150
60	120	180
64	128	192



<sup>1)</sup> Performance level 3 as per IEC 60 603-13,  $\geq 50$  mating cycles, no gas test  
Performance level 2 as per IEC 60 603-13,  $\geq 250$  mating cycles, 4 days gas test  
S4, plating  $> 0.76 \mu\text{m Au}$  (30  $\mu$  inch) or equivalent PdNi

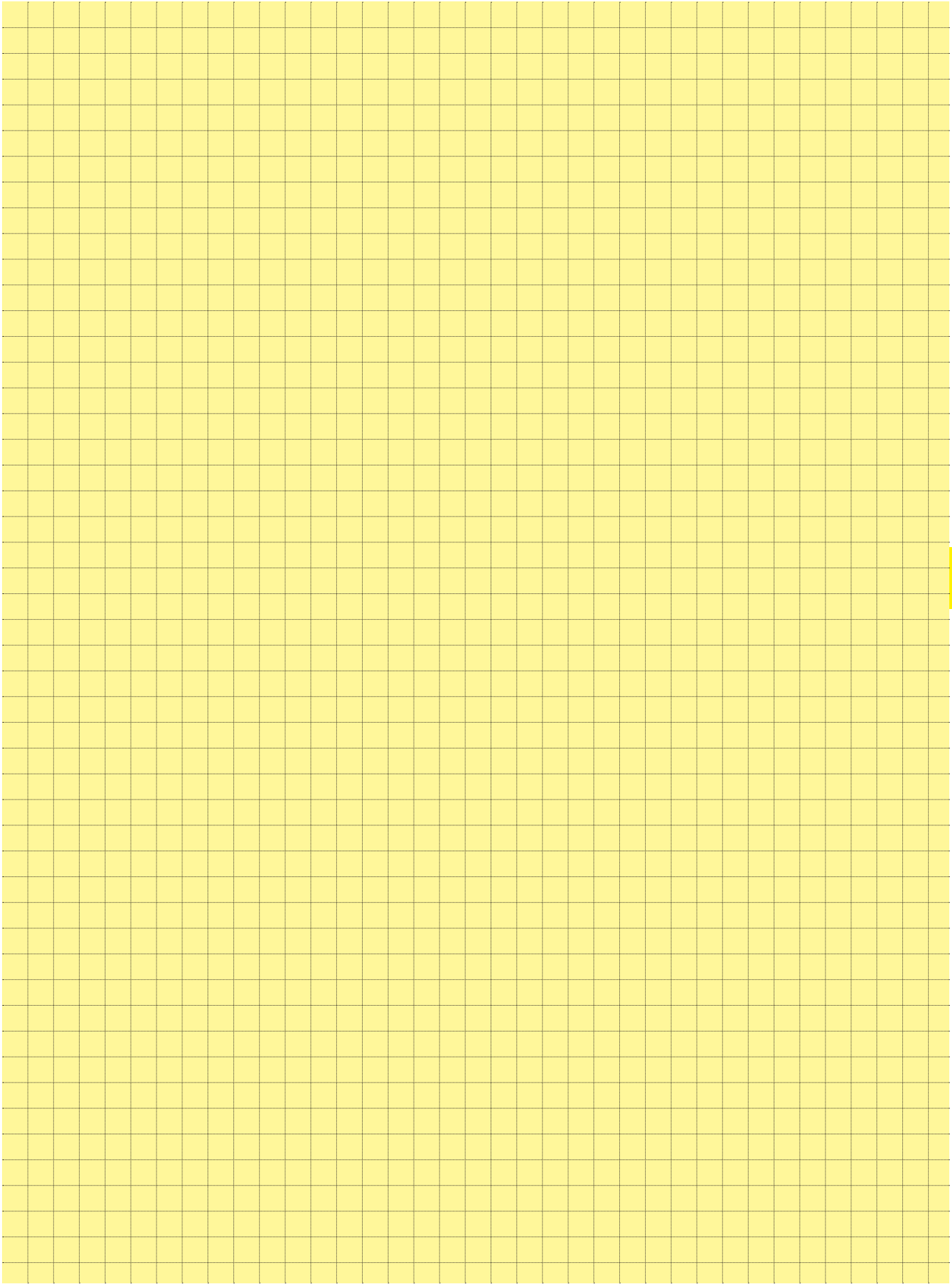

Number of contacts

6-64

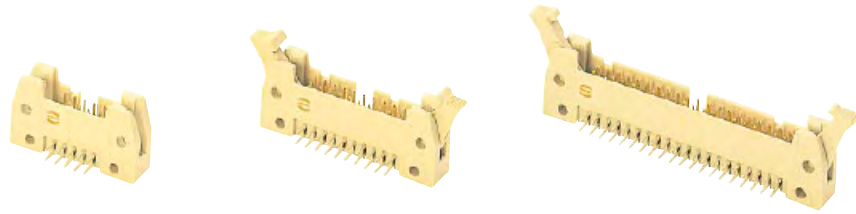

SMC male header with angled solder pins

Identification	No. of contacts	Part No.					
		Without levers		With short levers		With long levers	

SMC male header with angled solder pins  
Length: 2.9 mm

6	09 19 506	└ 923	09 19 506	└ 913	09 19 506	└ 903
10	09 19 510	└ 923	09 19 510	└ 913	09 19 510	└ 903
14	09 19 514	└ 923	09 19 514	└ 913	09 19 514	└ 903
16	09 19 516	└ 923	09 19 516	└ 913	09 19 516	└ 903
20	09 19 520	└ 923	09 19 520	└ 913	09 19 520	└ 903
26	09 19 526	└ 923	09 19 526	└ 913	09 19 526	└ 903
30	09 19 530	└ 923	09 19 530	└ 913	09 19 530	└ 903
34	09 19 534	└ 923	09 19 534	└ 913	09 19 534	└ 903
40	09 19 540	└ 923	09 19 540	└ 913	09 19 540	└ 903
50	09 19 550	└ 923	09 19 550	└ 913	09 19 550	└ 903
60	09 19 560	└ 923	09 19 560	└ 913	09 19 560	└ 903
64	09 19 564	└ 923	09 19 564	└ 913	09 19 564	└ 903

SEK

Kinked version on request

\* Not normally kept in stock  
For accessories see page 08.52  
For dimensions see page 08.43

For performance level 3 please specify digit  $\begin{matrix} \boxed{7} \\ \boxed{6} \\ \boxed{5} \end{matrix}$ \*  
For performance level 2 please specify digit  $\begin{matrix} \boxed{7} \\ \boxed{6} \\ \boxed{5} \end{matrix}$ \*

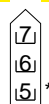
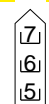

Number of contacts

# 6-64

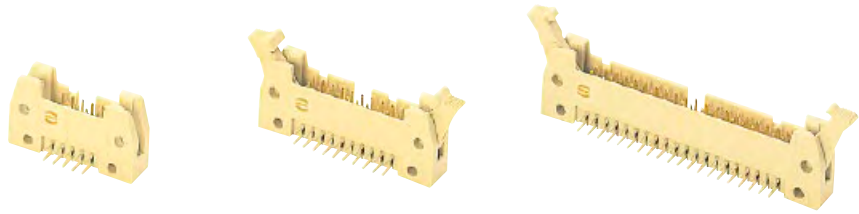

## SMC male header with angled solder pins

Identification

Drawing

Dimensions in mm

SMC male header

No. of contacts	A	B	D	E	F	G
6	26.9	16.76	12.45	2.54 x 2 = 5.08	36.9	40.3
10	32.0	21.84	17.53	2.54 x 4 = 10.16	42.0	45.4
14	37.1	26.92	22.61	2.54 x 6 = 15.24	47.1	50.4
16	39.6	29.46	25.15	2.54 x 7 = 17.78	49.6	53.0
20	44.7	34.54	30.23	2.54 x 9 = 22.86	54.7	58.1
26	52.3	42.16	37.85	2.54 x 12 = 30.48	62.3	65.7
30	57.7	47.24	43.83	2.54 x 14 = 35.56	68.2	68.6
34	62.5	52.32	48.01	2.54 x 16 = 40.64	72.5	75.8
40	70.1	59.94	55.63	2.54 x 19 = 48.26	80.1	83.5
50	82.8	72.64	68.33	2.54 x 24 = 60.96	92.8	96.2
60	95.5	85.34	81.03	2.54 x 29 = 73.66	105.5	108.9
64	100.6	90.42	86.11	2.54 x 31 = 78.74	110.6	113.9

### Short levers

for use with female connector without strain relief clamp

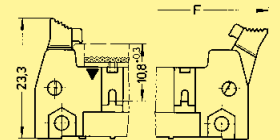
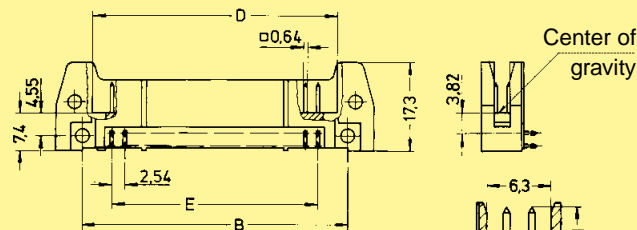

### Long levers

for use with female connector with strain relief clamp

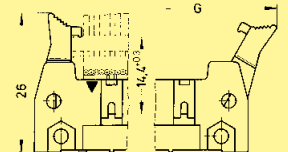
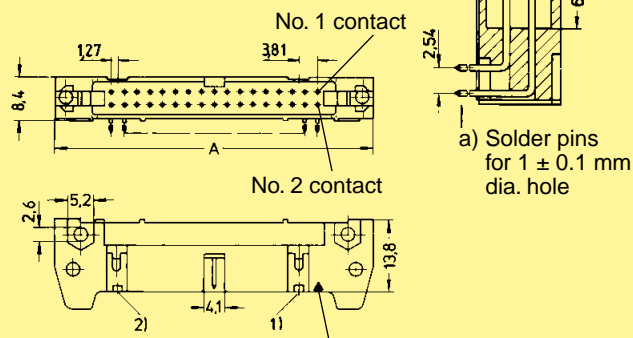

Marking No. 1 contact

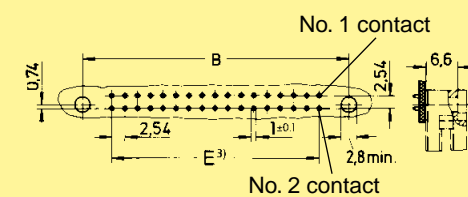

Board drillings

<sup>1)</sup> No polarization slot for 6, 10 or 14 way male header

<sup>2)</sup> No polarization slot for 6 way male header

<sup>3)</sup> Pitch tolerance: ± 0.1

Number of contacts

# 6-64

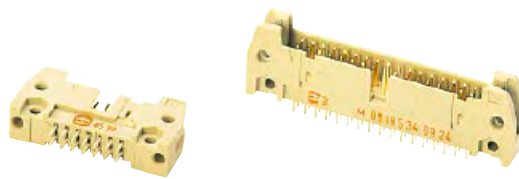

## SMC male header with straight solder pins

Identification	No. of contacts	Part No.					
		Without levers		With short levers		With long levers	
SMC male header with straight solder pins Length: 2.9 mm	6	09 19 506	└ 924	09 19 506	└ 914	09 19 506	└ 904
	10	09 19 510	└ 924	09 19 510	└ 914	09 19 510	└ 904
	14	09 19 514	└ 924	09 19 514	└ 914	09 19 514	└ 904
	16	09 19 516	└ 924	09 19 516	└ 914	09 19 516	└ 904
	20	09 19 520	└ 924	09 19 520	└ 914	09 19 520	└ 904
	26	09 19 526	└ 924	09 19 526	└ 914	09 19 526	└ 904
	30	09 19 530	└ 924	09 19 530	└ 914	09 19 530	└ 904
	34	09 19 534	└ 924	09 19 534	└ 914	09 19 534	└ 904
	40	09 19 540	└ 924	09 19 540	└ 914	09 19 540	└ 904
	50	09 19 550	└ 924	09 19 550	└ 914	09 19 550	└ 904
	60	09 19 560	└ 924	09 19 560	└ 914	09 19 560	└ 904
	64	09 19 564	└ 924	09 19 564	└ 914	09 19 564	└ 904

SEK

\* Not normally kept in stock  
 For accessories see page 08.52  
 For dimensions see page 08.45

For performance level 3 please specify digit  
 For performance level 2 please specify digit  
 S4 > 0.76 µm Au (30 µ inch) or equivalent PdNi

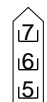

Number of contacts

# 6-64

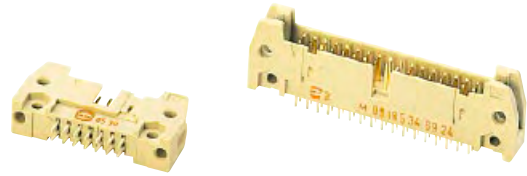

## SMC male header with straight solder pins

Identification

Drawing

Dimensions in mm

SMC male header

No. of contacts	A	C	D	E	F	G
6	26.9	22.86	12.45	2.54 x 2 = 5.08	36.9	40.3
10	32.0	27.94	17.53	2.54 x 4 = 10.16	42.0	45.4
14	37.1	33.02	22.61	2.54 x 6 = 15.24	47.1	50.4
16	39.6	35.56	25.15	2.54 x 7 = 17.78	49.6	53.0
20	44.7	40.64	30.23	2.54 x 9 = 22.86	54.7	58.1
26	52.3	48.26	37.85	2.54 x 12 = 30.48	62.3	65.7
30	57.7	53.34	43.83	2.54 x 14 = 35.56	68.2	68.6
34	62.5	58.42	48.01	2.54 x 16 = 40.64	72.5	75.8
40	70.1	66.04	55.63	2.54 x 19 = 48.26	80.1	83.5
50	82.8	78.74	68.33	2.54 x 24 = 60.96	92.8	96.2
60	95.5	91.44	81.03	2.54 x 29 = 73.66	105.5	108.9
64	100.6	96.52	86.11	2.54 x 31 = 78.74	110.6	113.9

### Short levers

for use with female connector without strain relief clamp

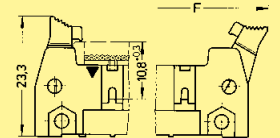
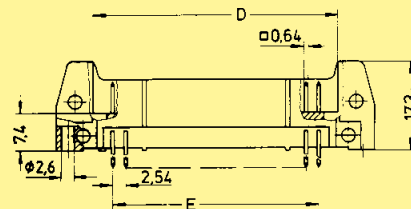

### Long levers

for use with female connector with strain relief clamp

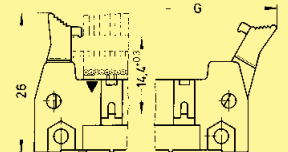
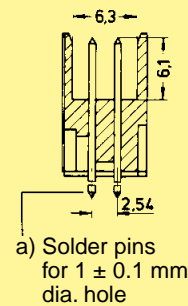
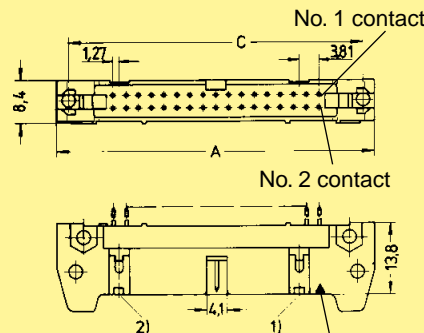

Marking No. 1 contact

### Board drillings

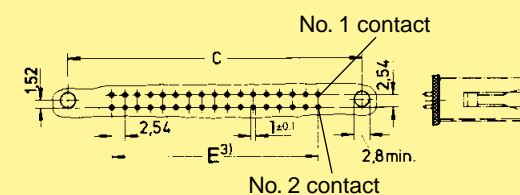

<sup>1)</sup> No polarization slot for 6, 10 or 14 way male header

<sup>2)</sup> No polarization slot for 6 way male header

<sup>3)</sup> Pitch tolerance: ± 0.1

Number of contacts

6-64

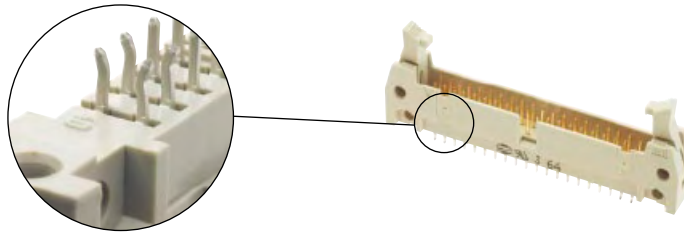

SMC male header with straight solder pins, kinked

Identification	No. of contacts	Part No.		
		Without levers	With short levers	With long levers

SMC male header with straight solder pins, kinked  
Length: 2.9 mm

6	09 19 506	└ 024	09 19 506	└ 014	09 19 506	└ 004
10	09 19 510	└ 024	09 19 510	└ 014	09 19 510	└ 004
14	09 19 514	└ 024	09 19 514	└ 014	09 19 514	└ 004
16	09 19 516	└ 024	09 19 516	└ 014	09 19 516	└ 004
20	09 19 520	└ 024	09 19 520	└ 014	09 19 520	└ 004
26	09 19 526	└ 024	09 19 526	└ 014	09 19 526	└ 004
30	09 19 530	└ 024	09 19 530	└ 014	09 19 530	└ 004
34	09 19 534	└ 024	09 19 534	└ 014	09 19 534	└ 004
40	09 19 540	└ 024	09 19 540	└ 014	09 19 540	└ 004
50	09 19 550	└ 024	09 19 550	└ 014	09 19 550	└ 004
60	09 19 560	└ 024	09 19 560	└ 014	09 19 560	└ 004
64	09 19 564	└ 024	09 19 564	└ 014	09 19 564	└ 004

SEK

\* Not normally kept in stock  
For accessories see page 08.52  
For dimensions see page 08.47

For performance level 3 please specify digit  
For performance level 2 please specify digit  
S4 > 0.76 µm Au (30 µ inch) or equivalent PdNi

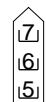
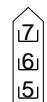
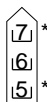

Number of contacts

# 6-64

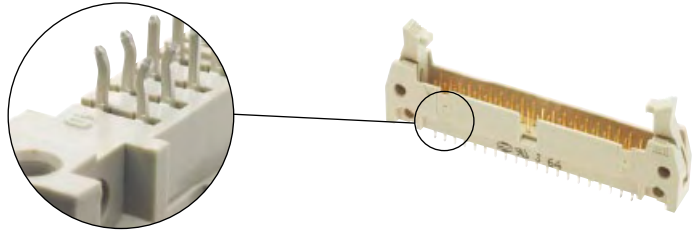

SMC male header with straight solder pins, kinked

Identification

Drawing

Dimensions in mm

SMC male header

No. of contacts	A	C	D	E	F	G
6	26.9	22.86	12.45	2.54 x 2 = 5.08	36.9	40.3
10	32.0	27.94	17.53	2.54 x 4 = 10.16	42.0	45.4
14	37.1	33.02	22.61	2.54 x 6 = 15.24	47.1	50.4
16	39.6	35.56	25.15	2.54 x 7 = 17.78	49.6	53.0
20	44.7	40.64	30.23	2.54 x 9 = 22.86	54.7	58.1
26	52.3	48.26	37.85	2.54 x 12 = 30.48	62.3	65.7
30	57.7	53.34	43.83	2.54 x 14 = 35.56	68.2	68.6
34	62.5	58.42	48.01	2.54 x 16 = 40.64	72.5	75.8
40	70.1	66.04	55.63	2.54 x 19 = 48.26	80.1	83.5
50	82.8	78.74	68.33	2.54 x 24 = 60.96	92.8	96.2
60	95.5	91.44	81.03	2.54 x 29 = 73.66	105.5	108.9
64	100.6	96.52	86.11	2.54 x 31 = 78.74	110.6	113.9

### Short levers

for use with female connector without strain relief clamp

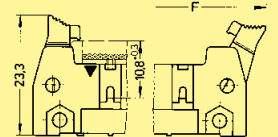
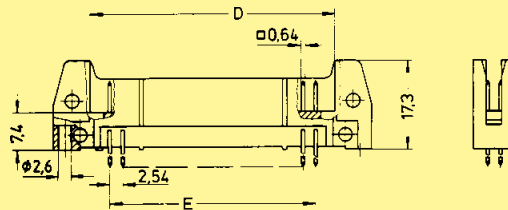

### Long levers

for use with female connector with strain relief clamp

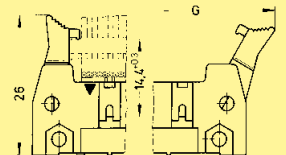
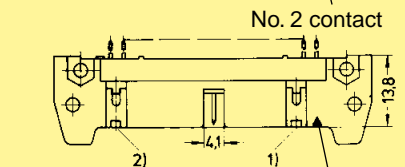
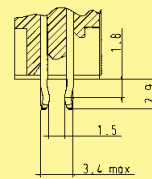
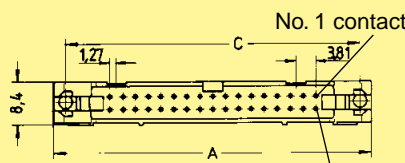

Marking No. 1 contact

No. 1 contact

Board drillings

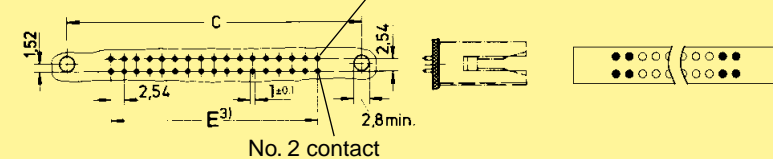

● Kinked contact: pcb thickness from 1.50 to 1.94 mm after Cu + Sn plating with non-remelted through holes  $\varnothing$  0.80 to  $\varnothing$  0.95 mm. Max. insertion force = 125 N. Min. retention force = 6 N.

○ Non-kinked contact: Solder pins for pcb connections  $\varnothing$  1 ± 0.1 mm as per IEC 60603-13.

<sup>1)</sup> No polarization slot for 6, 10 or 14 way male header

<sup>2)</sup> No polarization slot for 6 way male header

<sup>3)</sup> Pitch tolerance: ± 0.1



Number of contacts

# 6-64

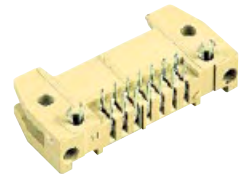

## SMC male header with angled solder pins and board lock

Identification	No. of contacts	Part No.					
		Without levers		With short levers		With long levers	
<p>SMC male header with angled solder pins and pcb board lock</p> <p>Length: 2.9 mm for 1.6 mm pcb thickness</p> <p>To hold the connector on the pcb before the soldering process, two board locks have been added on the male header with angled solder pins.</p>	6	09 19 506	└ 973*	09 19 506	└ 963*	09 19 506	└ 953*
	10	09 19 510	└ 973*	09 19 510	└ 963*	09 19 510	└ 953*
	14	09 19 514	└ 973*	09 19 514	└ 963*	09 19 514	└ 953*
	16	09 19 516	└ 973*	09 19 516	└ 963*	09 19 516	└ 953*
	20	09 19 520	└ 973*	09 19 520	└ 963*	09 19 520	└ 953*
	26	09 19 526	└ 973*	09 19 526	└ 963*	09 19 526	└ 953*
	30	09 19 530	└ 973*	09 19 530	└ 963*	09 19 530	└ 953*
	34	09 19 534	└ 973*	09 19 534	└ 963*	09 19 534	└ 953*
	40	09 19 540	└ 973*	09 19 540	└ 963*	09 19 540	└ 953*
	50	09 19 550	└ 973*	09 19 550	└ 963*	09 19 550	└ 953*
	60	09 19 560	└ 973*	09 19 560	└ 963*	09 19 560	└ 953*
	64	09 19 564	└ 973*	09 19 564	└ 963*	09 19 564	└ 953*

SEK

08  
48

\* Not normally kept in stock

For performance level 3 please specify digit  
 For performance level 2 please specify digit  
 S4 > 0.76 µm Au (30 µ inch) or equivalent PdNi

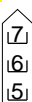
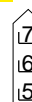
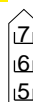

Number of contacts

# 6-64



## SMC male header with angled solder pins and board lock

Identification

Drawing

Dimensions in mm

SMC male header

No. of contacts	A	B	D	E	F	G
6	26.9	16.76	12.45	2.54 x 2 = 5.08	36.9	40.3
10	32.0	21.84	17.53	2.54 x 4 = 10.16	42.0	45.4
14	37.1	26.92	22.61	2.54 x 6 = 15.24	47.1	50.4
16	39.6	29.46	25.15	2.54 x 7 = 17.78	49.6	53.0
20	44.7	34.54	30.23	2.54 x 9 = 22.86	54.7	58.1
26	52.3	42.16	37.85	2.54 x 12 = 30.48	62.3	65.7
30	57.7	47.24	43.83	2.54 x 14 = 35.56	68.2	68.6
34	62.5	52.32	48.01	2.54 x 16 = 40.64	72.5	75.8
40	70.1	59.94	55.63	2.54 x 19 = 48.26	80.1	83.5
50	82.8	72.64	68.33	2.54 x 24 = 60.96	92.8	96.2
60	95.5	85.34	81.03	2.54 x 29 = 73.66	105.5	108.9
64	100.6	90.42	86.11	2.54 x 31 = 78.74	110.6	113.9

### Short levers

for use with female connector without strain relief clamp

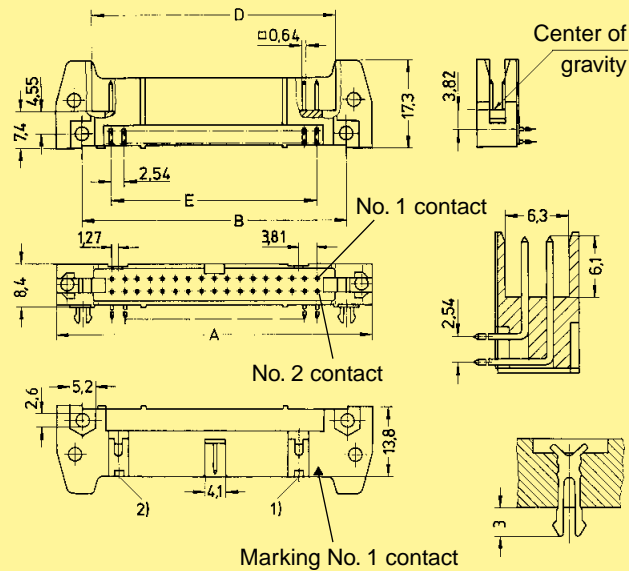

### Long levers

for use with female connector with strain relief clamp

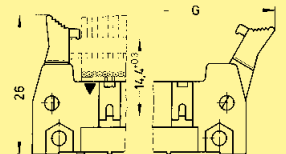

### Board drillings

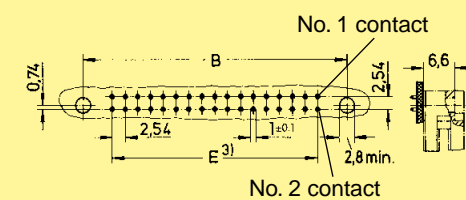

For accessories see page 08.52

<sup>1)</sup> No polarization slot for 6, 10 or 14 way male header

<sup>2)</sup> No polarization slot for 6 way male header

<sup>3)</sup> Pitch tolerance: ± 0.1

Number of contacts

# 6-64



Tape & Reel packaging

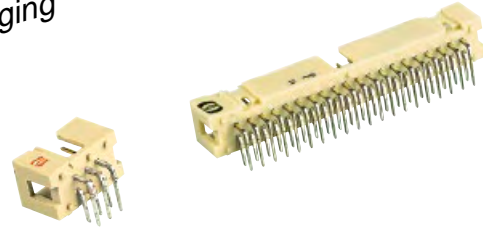

SMC low-profile male header, angled solder pins

Identification      No. of contacts      Part No.      Drawing      Dimensions in mm

SMC male header with angled solder pins

Length: 2.9 mm  
Colour: Beige  
Packaging: Carton

6	09 19 506	└ 323
10	09 19 510	└ 323
14	09 19 514	└ 323
16	09 19 516	└ 323
20	09 19 520	└ 323
26	09 19 526	└ 323
30	09 19 530	└ 323
34	09 19 534	└ 323
40	09 19 540	└ 323
50	09 19 550	└ 323
60	09 19 560	└ 323
64	09 19 564	└ 323

No. of contacts	A	B	E
6	15.2	12.78	2.54 x 2 = 5.08
10	20.3	17.86	2.54 x 4 = 10.16
14	25.4	22.94	2.54 x 6 = 15.24
16	27.9	25.48	2.54 x 7 = 17.78
20	33.0	30.56	2.54 x 9 = 22.86
26	40.6	38.18	2.54 x 12 = 30.48
30	45.72	43.26	2.54 x 14 = 35.56
34	50.8	48.34	2.54 x 16 = 40.64
40	58.4	55.96	2.54 x 19 = 48.26
50	71.3	68.66	2.54 x 24 = 60.96
60	84.0	81.36	2.54 x 29 = 73.66
64	89.1	86.44	2.54 x 31 = 78.74

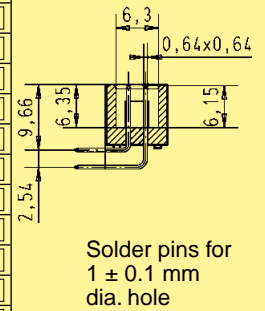

Colour: Beige  
Packaging: Tape & Reel

6	09 19 506	└ 323 740
10	09 19 510	└ 323 740
14	09 19 514	└ 323 740
16	09 19 516	└ 323 740
20	09 19 520	└ 323 740
26	09 19 526	└ 323 740
30	09 19 530	└ 323 740
34	09 19 534	└ 323 740
40	09 19 540	└ 323 740

Vacuum plate for pick & place process

Colour: Black  
Packaging: Tape & Reel

6	09 19 506	└ 323 741
10	09 19 510	└ 323 741
14	09 19 514	└ 323 741
16	09 19 516	└ 323 741
20	09 19 520	└ 323 741
26	09 19 526	└ 323 741
30	09 19 530	└ 323 741
34	09 19 534	└ 323 741
40	09 19 540	└ 323 741

Vacuum plate for pick & place process

For performance level 3 please specify digit  
For performance level 2 please specify digit  
S4 > 0.76 µm Au (30 µ inch) or equivalent PdNi

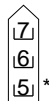

Marking No. 1 contact

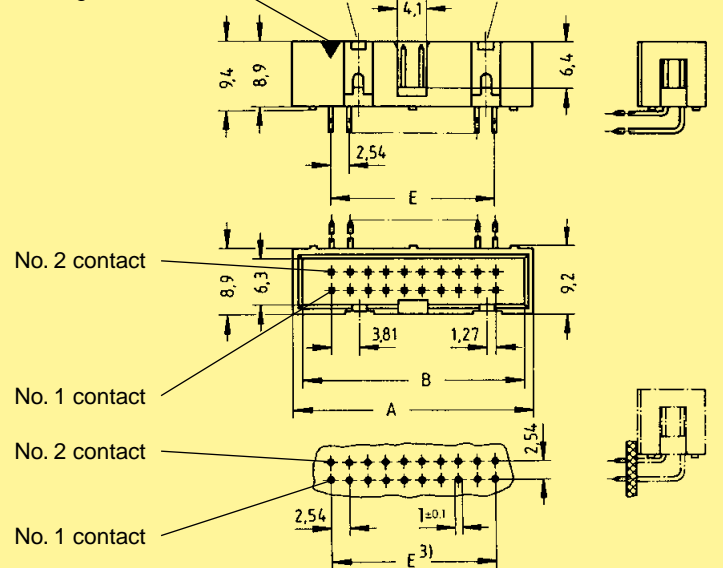

Identification      Part No.      Drawing      Dimensions in mm

Locking lever for female connector with strain relief  
in conjunction with low-profile male header

09 18 000 9905<sup>4)</sup>

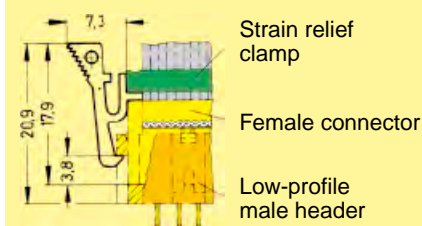

When the security of latching is required and space is a premium, these locking levers can be fitted onto the strain relief of the HARTING female connector.

\* Not normally kept in stock

<sup>1)</sup> No polarization slot for 6, 10 or 14 way male header  
<sup>2)</sup> No polarization slot for 6 way male header

<sup>3)</sup> Pitch tolerance: ± 0.1  
<sup>4)</sup> Order 2 per female connector

Number of contacts

**6-64**



Tape & Reel packaging

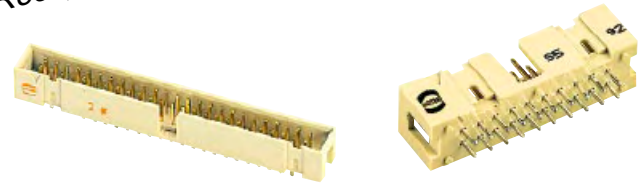

SMC low-profile male header, straight solder pins

Identification      No. of contacts      Part No.      Drawing      Dimensions in mm

SMC male header with straight solder pins

Length: 2.9 mm  
Colour: Beige  
Packaging: Carton

No. of contacts	Part No.
6	09 19 506 □ 324
10	09 19 510 □ 324
14	09 19 514 □ 324
16	09 19 516 □ 324
20	09 19 520 □ 324
26	09 19 526 □ 324
30	09 19 530 □ 324
34	09 19 534 □ 324
40	09 19 540 □ 324
50	09 19 550 □ 324
60	09 19 560 □ 324
64	09 19 564 □ 324

No. of contacts	A	B	E
6	15.2	12.78	2.54 x 2 = 5.08
10	20.3	17.86	2.54 x 4 = 10.16
14	25.4	22.94	2.54 x 6 = 15.24
16	27.9	25.48	2.54 x 7 = 17.78
20	33.0	30.56	2.54 x 9 = 22.86
26	40.6	38.18	2.54 x 12 = 30.48
30	45.72	43.26	2.54 x 14 = 35.56
34	50.8	48.34	2.54 x 16 = 40.64
40	58.4	55.96	2.54 x 19 = 48.26
50	71.3	68.66	2.54 x 24 = 60.96
60	84.0	81.36	2.54 x 29 = 73.66
64	89.1	86.44	2.54 x 31 = 78.74

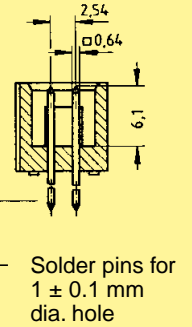

Colour: Beige  
Packaging: Tape & Reel

Vacuum plate for pick & place process

6	09 19 506 □ 324 740
10	09 19 510 □ 324 740
14	09 19 514 □ 324 740
16	09 19 516 □ 324 740
20	09 19 520 □ 324 740
26	09 19 526 □ 324 740
30	09 19 530 □ 324 740
34	09 19 534 □ 324 740
40	09 19 540 □ 324 740

Colour: Black  
Packaging: Tape & Reel

Vacuum plate for pick & place process

6	09 19 506 □ 324 741
10	09 19 510 □ 324 741
14	09 19 514 □ 324 741
16	09 19 516 □ 324 741
20	09 19 520 □ 324 741
26	09 19 526 □ 324 741
30	09 19 530 □ 324 741
34	09 19 534 □ 324 741
40	09 19 540 □ 324 741

Marking No. 1 contact

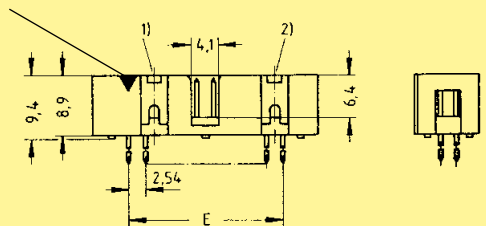

No. 2 contact

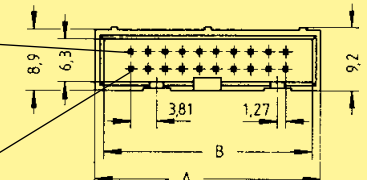

No. 1 contact

No. 2 contact

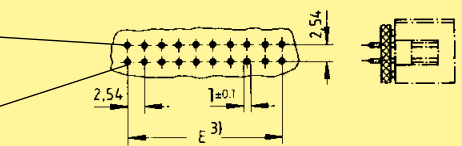

No. 1 contact

For performance level 3 please specify digit  
For performance level 2 please specify digit  
S4 > 0.76 µm Au (30 µ inch) or equivalent PdNi



Identification      Part No.      Drawing      Dimensions in mm

Locking lever for female connector with strain relief in conjunction with low-profile male header

09 18 000 9905<sup>4)</sup>

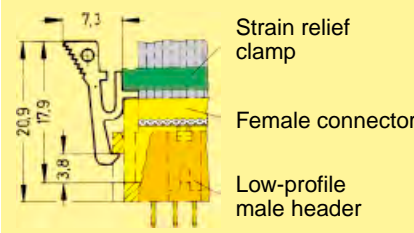

When the security of latching is required and space is a premium, these locking levers can be fitted onto the strain relief of the HARTING female connector.

\* Not normally kept in stock

<sup>1)</sup> No polarization slot for 6, 10 or 14 way male header  
<sup>2)</sup> No polarization slot for 6 way male header

<sup>3)</sup> Pitch tolerance: ± 0.1  
<sup>4)</sup> Order 2 per female connector

Accessories

Identification	Part No.	Drawing	Dimensions in mm
<p>Polarization key</p> <p>1) Part No. comprises 2 keys</p>	09 18 500 9902 <sup>1)</sup>		
<p>Locking lever (snaps into place, can be fitted whenever required)</p> <p>2) Order 2 per male header</p>	<p>Long: 09 19 000 9903<sup>2)</sup></p> <p>Short: 09 19 000 9904<sup>2)</sup></p>	<p>Long</p> <p>Short</p> <p>For use with female connector <u>with</u> strain relief clamp</p> <p>For use with female connector <u>without</u> strain relief clamp</p>	
<p>Fixing screws for 1.6 mm P.C. board</p> <p>3) Part No. comprises 50 pieces</p>	09 18 000 9906 <sup>3)</sup>		<p>For connectors with part numbers 09 18 5xx x9xx: screwing torque 0.2 Nm 09 19 5xx x9xx: screwing torque 0.4 – 0.5 Nm</p> <p>Screw material: Steel (Inox A2)</p> <p>Plating: Nickel</p>
<p>Coding system with loss of contact</p> <p>Code pin</p> <p>4) Part No. comprises 6 code pins</p>	09 18 000 9901 <sup>4)</sup>	<p>To avoid cross-plugging adjacent connectors a coding system is required. A code pin is inserted into the appropriate cavity in the female connector. The corresponding male contact is removed by a special removal tool.</p>	

SEK

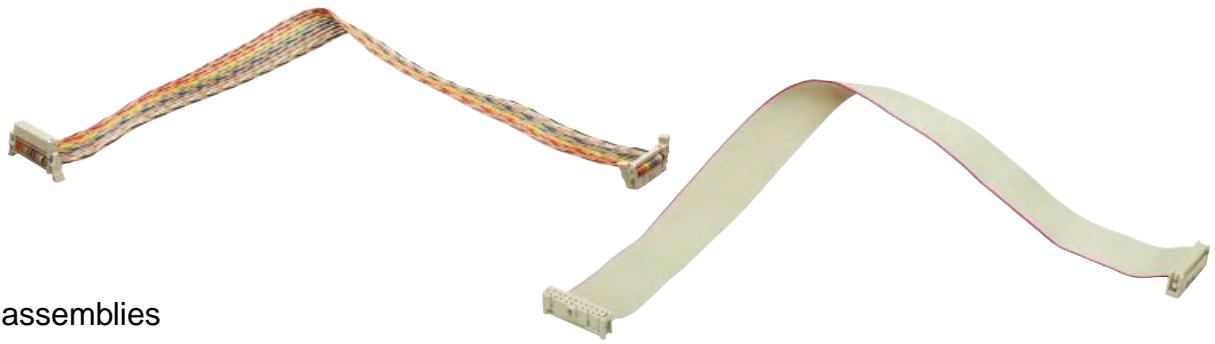

## Cable assemblies

Identification	Part No.	Drawing	Dimensions in mm
<p><b>Cable assembly SEK</b> <b>20-pole</b></p> <p>Cable: Flat cable, 10 twisted pairs, AWG 28/7, 1.27 mm pitch</p> <p>Wiring: 1:1</p> <p>Length: L = 0.5 m L = 1.0 m L = 1.5 m</p>	<p>33 18 243 0500 060 33 18 243 1000 062 33 18 243 1500 068</p>		
<p><b>Cable assembly SEK</b> <b>40-pole</b></p> <p>Cable: Flat cable, 20 twisted pairs, AWG 28/7, 1.27 mm pitch</p> <p>Wiring: 1:1</p> <p>Length: L = 0.5 m L = 1.0 m L = 1.5 m</p>	<p>33 18 243 0500 055 33 18 243 1000 057 33 18 243 1500 069</p>		
<p><b>Cable assembly SEK</b> <b>10-pole</b></p> <p>Cable: Flat cable, grey, 10 wires, AWG 28/7, 1.27 mm pitch</p> <p>Wiring: 1:1</p> <p>Length: L = 0.1 m L = 0.2 m L = 0.5 m L = 0.8 m L = 1.0 m</p>	<p>33 18 243 0100 063 33 18 243 0200 064 33 18 243 0500 065 33 18 243 0800 066 33 18 243 1000 067</p>		

## Cables for insulation displacement termination

Identification	No. of contacts	Part No.	Drawing	Dimensions in mm			
<b>Flat cable</b> grey UL AWM-style 2651 CSA	6	09 18 006 700		Conductor material _____ Copper tinned Gauge _____ AWG 28/7 0.089 mm <sup>2</sup> Voltage rating _____ 300 V <sub>r.m.s.</sub> Current rating at 25 °C _____ 2.1 A max. Capacity unbalanced _____ 45.9 pF/m Impedance unbalanced _____ 105 Ω Propagation delay _____ 4.9 ns/m nominal Insulation material _____ PVC Temperature rating (operating) _____ -20 °C ... +105 °C Temperature rating (static) _____ -30 °C ... +105 °C Flammability rating _____ UL: VW-1 Insulation resistance _____ > 100 MΩ/km			
	9	09 18 009 700					
	10	09 18 010 700					
	14	09 18 014 700					
	15	09 18 015 700					
	16	09 18 016 700					
	18	09 18 018 700					
	20	09 18 020 700					
	24	09 18 024 700					
	25	09 18 025 700					
	26	09 18 026 700					
	28	09 18 028 700					
	30	09 18 030 700					
	34	09 18 034 700					
	37	09 18 037 700					
	40	09 18 040 700					
	50	09 18 050 700					
	60	09 18 060 700					
	64	09 18 064 700					
	Length per reel						
	30.48 m (100 feet)	1					
	100 m (328 feet)	4					
	<b>Flat cable</b> grey non-halogenated	6			09 18 006 700		Conductor material _____ Copper tinned Gauge _____ AWG 28/7 0.089 mm <sup>2</sup> Voltage rating _____ 300 V <sub>r.m.s.</sub> Current rating _____ 1.3 A Capacity unbalanced _____ 42.7 pF/m at 1 MHz Impedance unbalanced _____ 100 Ω Inductance _____ 0.56 mH/m Propagation delay _____ 4.8 ns/m Insulation material _____ Non-halogenated flame retardent Polyolefin Temperature rating _____ -40 °C ... +90 °C Insulation resistance _____ 10000 MΩ/km
		9			09 18 009 700		
10		09 18 010 700					
14		09 18 014 700					
15		09 18 015 700					
16		09 18 016 700					
18		09 18 018 700					
20		09 18 020 700					
24		09 18 024 700					
25		09 18 025 700					
26		09 18 026 700					
28		09 18 028 700					
34		09 18 034 700					
37		09 18 037 700					
40		09 18 040 700					
50		09 18 050 700					
60		09 18 060 700					
64		09 18 064 700					
Length per reel							
30.48 m (100 feet)		1					
100 m (328 feet)		4					

SEK

## Cables for insulation displacement termination

Identification	No. of contacts	Part No.	Drawing	Dimensions in mm
<b>Flat cable</b> colour coded  Length per reel 30.48 m (100 feet)  UL AWM-style 2651	6 9 10 14 15 16 18 20 24 25 26 28 30 34 37 40 50 60 64	09 18 006 7005 09 18 009 7005 09 18 010 7005 09 18 014 7005 09 18 015 7005 09 18 016 7005 09 18 018 7005 09 18 020 7005 09 18 024 7005 09 18 025 7005 09 18 026 7005 09 18 028 7005 09 18 030 7005 09 18 034 7005 09 18 037 7005 09 18 040 7005 09 18 050 7005 09 18 060 7005 09 18 064 7005	<p>AWG 28/7 colour coded <math>1,27 \pm 0,05</math> 0,5 <math>(n-1) \times 1,27</math> 1,00</p>	Colour code sequence (in 10 steps)  brown, red, orange, yellow, green, blue, violet, grey, white, black  <p>Conductor material _____ Copper tinned                      Gauge _____ AWG 28/7 0.09 mm<sup>2</sup>                      Voltage rating _____ 300 V<sub>r.m.s.</sub>                      Current rating at 25 °C _____ 2.1 A max.                      Conductor resistance _____ 221 mΩ/m                      Capacity unbalanced _____ 42.7 pF/m                      Impedance unbalanced _____ 105 Ω                      Inductance unbalanced _____ 0.68 μH/m                      Signal delay _____ 4.9 ns/m                      Insulation material _____ PVC                      Temperature rating (operating) _____ -20 °C ... +105 °C                      Temperature rating (static) _____ -30 °C ... +105 °C                      Flammability rating _____ UL: VW 1                      Insulation resistance _____ 100 MΩ/km</p>
<b>Flat cable</b> twisted pair  Length per reel 30.48 m (100 feet)  UL AWM-style 20 130	10 14 16 20 26 34 40 50 60 64	09 18 010 7006 09 18 014 7006 09 18 016 7006 09 18 020 7006 09 18 026 7006 09 18 034 7006 09 18 040 7006 09 18 050 7006 09 18 060 7006 09 18 064 7006	<p>colour coded AWG 28/7 <math>1,27 \pm 0,13</math> <math>1,02 \pm 0,13</math> <math>(n-1) \times 1,27</math> 1,07</p> <p>457,2 50,8 508</p>	<p>Conductor material _____ Copper tinned                      Gauge _____ AWG 28/7 0.089 mm<sup>2</sup>                      Voltage rating _____ 300 V<sub>r.m.s.</sub>                      Conductor resistance _____ 221 mΩ/m                      Capacity unbalanced _____ 49 pF/m                      Impedance unbalanced _____ 105 Ω                      Signal delay _____ 5.2 ns/m                      Insulation material _____ PVC                      Temperature rating _____ -20 °C ... +105 °C                      Flammability rating _____ UL: VW 1                      Insulation resistance _____ 10<sup>4</sup> MΩ/km</p>

Important: always store reel vertically

SEK



## Cables for insulation displacement termination

Identification	No. of contacts	Part No.	Drawing	Dimensions in mm
<b>Round flat cable</b>				
with screening (shielding)				
	9	09 18 009 70		6.86
	10	09 18 010 70		6.86
	14	09 18 014 70		7.37
	15	09 18 015 70		7.62
UL listed PLCC CL2 CSA certified AWM FT-1				
	16	09 18 016 70		7.87
	20	09 18 020 70		8.38
	25	09 18 025 70		9.14
	26	09 18 026 70		9.14
	34	09 18 034 70		10.16
	37	09 18 037 70		10.41
	40	09 18 040 70		10.92
Length per reel				
30.48 m (100 feet)	07	09 18 064 70		13.21
100 m (328 feet)	10*	09 18 064 70		13.46
without screening (shielding)				
	9	09 18 009 70		6.35
	10	09 18 010 70		6.35
	14	09 18 014 70		6.60
	15	09 18 015 70		6.86
UL listed PLCC CL2 CSA certified AWM FT-1				
	16	09 18 016 70		7.11
	20	09 18 020 70		7.62
	25	09 18 025 70		8.38
	26	09 18 026 70		8.38
	34	09 18 034 70		9.40
	37	09 18 037 70		9.65
	40	09 18 040 70		10.16
Length per reel				
30.48 m (100 feet)	08	09 18 064 70		12.45
100 m (328 feet)	11*	09 18 064 70		12.70

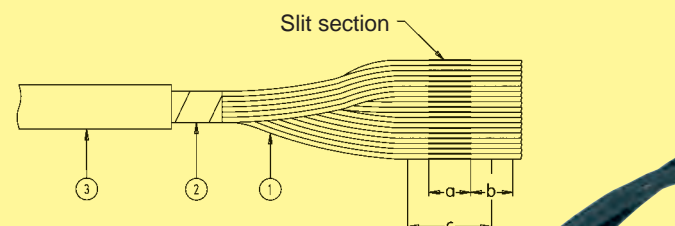
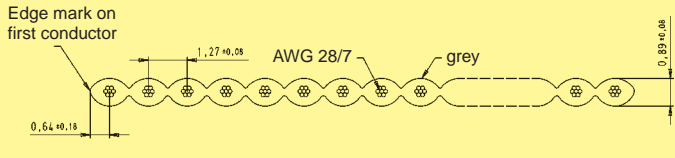
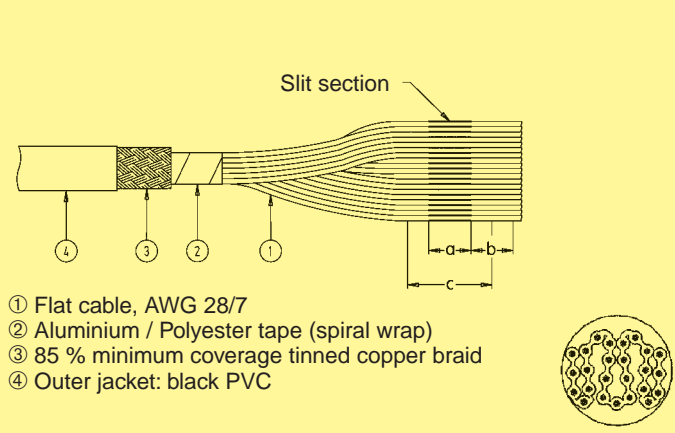

No. of contacts	a	b	c
9 to 26	19.05	19.05	38.10
34 to 64	38.10	19.05	57.15

- Conductor material \_\_\_\_\_ Copper tinned
- Gauge \_\_\_\_\_ AWG 28/7 0.089 mm<sup>2</sup>
- Voltage rating \_\_\_\_\_ 300 V<sub>r.m.s.</sub>
- Conductor resistance \_\_\_\_\_ 225 mΩ/m
- Capacity unbalanced \_\_\_\_\_ 78.7 pF/m
- Impedance unbalanced \_\_\_\_\_ 75 Ω
- Signal delay \_\_\_\_\_ 5.25 ns/m nom.
- Insulation material \_\_\_\_\_ PVC
- Temperature rating \_\_\_\_\_ -20 °C ... +105 °C
- Flammability rating \_\_\_\_\_ UL: VW 1
- Insulation resistance \_\_\_\_\_ 10<sup>4</sup> MΩ/km

SEK

\* Not normally kept in stock  
Important: always store reels vertically

